

Thank you for purchasing this Esco CO₂ Incubator. Please read this manual thoroughly to familiarize yourself with the many unique features and exciting innovations we have built into your new equipment.

Esco provides many other resources at www.escolifesciences.com, to complement this manual and help you enjoy many years of productive and safe use of Esco Products.



User Manual

CEL CULTURE[®]
CO₂ Incubators



 **Esco Micro Pte. Ltd.**
19 Changi South Street 1 • Singapore 486 779
Tel +65 6542 0833
www.escolifesciences.com • mail@escolifesciences.com

**For Technical Service, contact
NORTH AMERICA**

Esco Technologies, Inc.
903 Sheehy Drive, Suite F, Horsham, PA 19044, USA
Tel 215-441-9661 • Fax 484-698-7757
www.escolifesciences.us • eti.admin@escolifesciences.com

REST OF THE WORLD

Esco Micro Pte. Ltd.
19 Changi South Street 1, Singapore 486 779
Tel +65 6542 0833
www.escolifesciences.com • mail@escolifesciences.com

Copyright Information

© Copyright 2024 Esco Micro Pte. Ltd. All rights reserved.

The information contained in this manual and the accompanying product is copyrighted and all rights are reserved by Esco.

Esco reserves the right to make periodic minor design changes without obligation to notify any person or entity of such change.

CelCulture® is a registered trademark of Esco.

Only to be used by a trained and qualified professional. For research purposes only.

“Material in this manual is provided for informational purposes only. The contents and the product described in this manual (including any appendix, addendum, attachment, or inclusion), are subject to change without notice. Esco makes no representations or warranties as to the accuracy of the information contained in this manual. In no event shall Esco be held liable for any damages, direct or consequential, arising out of or related to the use of this manual.”

Table of Contents

Warranty Terms and Conditions	v
Introduction.....	vii
1. Products Covered.....	vii
2. Safety Warning.....	ix
3. Document Management.....	ix
4. Limitation of Liability.....	x
5. European Union Directive on WEEE and RoHS.....	x
6. Symbols.....	x
7. Packaging.....	xi
Chapter 1 - Product Information	xi
1.1. Intended Purpose	1
1.2. Product Description	1
1.3. Labels	2
1.4. Quick View	2
1.4.1. Front Quick View (CCL-050_-_-).....	2
1.4.2. Front Quick View (CCL-170_-_-, CCL-240_-_-).....	3
1.4.3. Front Quick View (CCL-170_-_-UV, CCL-170_-_-P-UV, CCL-240_-_-UV, CCL-240_-_-P-UV).....	4
1.4.4. Back Quick View (CCL-050_-_-_, CCL-170_-_-_, CCL-240_-_-_, CCL-170_-_-UV, CCL-240_-_-UV).....	5
1.4.5. Back Quick View (CCL-170_-_-P, CCL-240_-_-P, CCL-170_-_-P-UV, CCL-240_-_-P-UV).....	6
Chapter 2 – Installation.....	7
2.1. General Requirements.....	7
2.1.1. Location Requirements.....	7
2.1.2. Environmental Requirements.....	8
2.1.3. Power Requirements.....	8
2.2. Installation.....	9
2.2.1. Unit Leveling.....	9
2.2.2. Unit Stacking.....	9
2.2.3. ULPA Filter Installation (For 170L & 240L).....	9
2.2.4. Shelves System Installation.....	12
2.2.5. Connecting the Unit to Electrical Power.....	12
2.2.6. Connecting the Unit to CO ₂ and N ₂ Gas Supply.....	12
2.2.7. Connecting Alarm Contacts and RS485 Communication Port.....	13
2.2.8. Connecting Esco Voyager® Software.....	13
2.3. Preliminary Cleaning.....	13
2.4. Filling the Water pan.....	13
2.5. Filtered Air Exchange (For 170L & 240L).....	14
2.6. Use of Additional Devices in the CO ₂ Incubator.....	15
2.7. First Run.....	15
2.8. UV Lamp Functionality (For CCL-UV units).....	16
2.9. Replacing Old CO ₂ Sensor to the Latest IR Sensor.....	16
2.10. Disclaimer.....	16
Chapter 3 - Control System and Operation	17
3.1. CelCulture® Control System.....	17

- 3.2. Menu Options 19
 - 3.2.1. Settings..... 20
 - 3.2.2. Calibration..... 20
 - 3.2.3. Admin..... 23
 - 3.2.4. Data Logging..... 26
 - 3.2.5. Service..... 26
 - 3.2.6. Help 26
- 3.3. Operation of CO₂ Incubator with Peltier Cooling System (applicable for CCL-P series) 27
 - 3.3.1. Cooling Mode 27
 - 3.3.2. Heating Mode 27
- 3.4. Diagnostic Readout..... 28
- 3.5. Alarm 29
- Chapter 4 - General Maintenance 30**
 - 4.1. Scheduled Maintenance 30
 - 4.1.1. Check CO₂/N₂ Gas Tank Level..... 30
 - 4.1.2. Check Water Level in the Water pan 30
 - 4.1.3. Cleaning and Decontamination..... 30
 - 4.1.4. General Inspection 30
 - 4.1.5. Calibration of Temperature, CO₂, O₂ and Humidity 30
 - 4.1.6. Change ULPA Filter (CCL-170L & CCL-240L only) 31
 - 4.1.7. Change Inlet Filter 31
 - 4.1.8. Change Outer Door Magnetic Gasket 31
 - 4.1.9. Change UV Lamp (for units with UV lamp) 31
 - 4.2. Maintenance/Service Log 31
- Chapter 5 - Cleaning & Decontamination 32**
 - 5.1. Cleaning Procedure..... 32
 - 5.2. Decontamination 34
 - 5.2.1. Decontamination Procedure..... 34
- Chapter 6 - Troubleshooting 36**
- Chapter 7 – Technical Specifications 41**
- APPENDIX 42**

Warranty Terms and Conditions

Esco products come with a limited warranty. The warranty period will vary depending on the product purchased, beginning on the date of shipment from any Esco international warehousing location. To determine which warranty applies to your product, refer to the appendix below.

Esco's limited warranty covers defects in materials and workmanship. Esco's liability under this limited warranty shall be, at our option, to repair or replace any defective parts of the equipment, provided if proven to the satisfaction of Esco that these parts were defective at the time of being sold, and that all defective parts shall be returned, properly identified with a Return Authorization.

This limited warranty covers parts only, and not transportation/insurance charges.

This limited warranty does not cover:

- Freight or installation (inside delivery handling) damage. If your product was damaged in transit, you must file a claim directly with the freight carrier.
- Products with missing or defaced serial numbers.
- Products for which Esco has not received payment.
- Problems that result from:
 - External causes such as accident, abuse, misuse, problems with electrical power, improper operating environmental conditions.
 - Servicing not authorized by Esco.
 - Usage that is not in accordance with product instructions.
 - Failure to follow the product instructions.
 - Failure to perform preventive maintenance.
 - Problems caused by using accessories, parts, or components not supplied by Esco.
 - Damage by fire, floods, or acts of God.
 - Customer modifications to the product
- Consumables such as filters (HEPA, ULPA, carbon, pre-filters) and fluorescent / UV bulbs.
- **Esco is not liable for any damage incurred on the objects used on or stored in Esco equipment. If the objects are highly valuable, the use of a completely independent backup system and a 24-hr redundant monitoring system with alarm capability are recommended.**

Factory installed, customer specified equipment or accessories are warranted only to the extent guaranteed by the original manufacturer. The customer agrees that in relation to these products purchased through Esco, our limited warranty shall not apply and the original manufacturer's warranty shall be the sole warranty in respect of these products. The customer shall utilize that warranty for the support of such products and in any event not look to Esco for such warranty support.

Esco encourages all users to register their equipment online at [www.https://www.escolifesciences.com/services/warranty-registration](https://www.escolifesciences.com/services/warranty-registration) or complete the warranty registration form included with each product.

ALL EXPRESS AND IMPLIED WARRANTIES FOR THE PRODUCT, INCLUDING BUT NOT LIMITED TO ANY IMPLIED WARRANTIES AND CONDITIONS OF MERCHANTABILITY AND FITNESS FOR A PARTICULAR PURPOSE ARE LIMITED IN TIME TO THE TERM OF THIS LIMITED WARRANTY. NO WARRANTIES, WHETHER EXPRESS OR IMPLIED, WILL APPLY AFTER THE LIMITED WARRANTY PERIOD HAS EXPIRED. ESCO DOES NOT ACCEPT LIABILITY BEYOND THE REMEDIES PROVIDED FOR IN THIS LIMITED WARRANTY OR FOR SPECIAL, INDIRECT, CONSEQUENTIAL OR INCIDENTAL DAMAGES, INCLUDING, WITHOUT LIMITATION, ANY LIABILITY FOR THIRD-PARTY CLAIMS AGAINST YOU FOR DAMAGES, FOR PRODUCTS NOT BEING AVAILABLE FOR USE, OR FOR LOST WORK. ESCO'S LIABILITY WILL BE NO MORE THAN THE AMOUNT YOU PAID FOR THE PRODUCT THAT IS THE SUBJECT OF A CLAIM. THIS IS THE MAXIMUM AMOUNT FOR WHICH ESCO IS RESPONSIBLE.

These Terms and Conditions shall be governed by and construed in accordance with the laws of Singapore and shall be subject to the exclusive jurisdiction of the courts of Singapore.

Technical Support, Warranty Service Contacts

USA: 1 215-441-9661

Singapore: +65 6542 0833

Global Email Helpdesk: support-co2@escolifesciences.comFor more information, visit <http://www.escolifesciences.com/>.Distributors are encouraged to visit www.escoglobal.net for additional materials.**Product Appendix, Warranty Listing**

CO ₂ Incubators	2 years limited
----------------------------	-----------------

Note: The warranty periods may vary by country. Contact your local distributor for specific warranty details.

For international distributors, warranty period starts two months from the date the equipment is shipped from Esco facility. This allows shipping time so the warranty will go into effect at approximately the same time the equipment is delivered to the user. The warranty protection extends to any subsequent owner during the warranty period. Distributors who stock Esco equipment are allowed an additional four months for delivery and installation, providing the product is registered with Esco. User can register their products online at <https://www.escolifesciences.com/services/warranty> or complete the warranty registration form include with each product.

Policy updated on 1st January 2015 (This limited warranty policy applies to products purchased on and after 1st January 2015)

Introduction

1. Products Covered

CelCulture® CO ₂ Incubator (Stainless Steel Chamber with Curved Door)								
Model	Size	Sensor	Control	Filter	Decontamination	Electrical Rating	Water Pan Cover	
							Yes/No	Code
CCL-050B-8	50 L	IR	CO ₂	N/A	90°C Moist Heat	220 - 240 V, AC, 50/60 Hz, 1Φ	Yes	B
CCL-050B-8-SS	50 L	IR	CO ₂	N/A	90°C Moist Heat	220 - 240 V, AC, 50/60 Hz, 1Φ	Yes	B
CCL-050B-9	50 L	IR	CO ₂	N/A	90°C Moist Heat	110 - 130 V, AC, 50/60 Hz, 1Φ	Yes	B
CCL-050B-9-SS	50 L	IR	CO ₂	N/A	90°C Moist Heat	110 - 130 V, AC, 50/60 Hz, 1Φ	Yes	B
CCL-050T-8	50 L	IR	CO ₂ /O ₂	N/A	90°C Moist Heat	220 - 240 V, AC, 50/60 Hz, 1Φ	Yes	T
CCL-050T-8-SS	50 L	IR	CO ₂ /O ₂	N/A	90°C Moist Heat	220 - 240 V, AC, 50/60 Hz, 1Φ	Yes	T
CCL-050T-9	50 L	IR	CO ₂ /O ₂	N/A	90°C Moist Heat	110 - 130 V, AC, 50/60 Hz, 1Φ	Yes	T
CCL-050T-9-SS	50 L	IR	CO ₂ /O ₂	N/A	90°C Moist Heat	110 - 130 V, AC, 50/60 Hz, 1Φ	Yes	T
CCL-170B-8	170 L	IR	CO ₂	ULPA	90°C Moist Heat	220 - 240 V, AC, 50/60 Hz, 1Φ	Yes	L7B
CCL-170B-8-NF	170 L	IR	CO ₂	N/A	90°C Moist Heat	220 - 240 V, AC, 50/60 Hz, 1Φ	Yes	L7B
CCL-170B-8-SS	170 L	IR	CO ₂	ULPA	90°C Moist Heat	220 - 240 V, AC, 50/60 Hz, 1Φ	Yes	L7B
CCL-170B-9	170 L	IR	CO ₂	ULPA	90°C Moist Heat	110 - 130 V, AC, 50/60 Hz, 1Φ	Yes	L7B
CCL-170B-9-NF	170 L	IR	CO ₂	N/A	90°C Moist Heat	110 - 130 V, AC, 50/60 Hz, 1Φ	Yes	L7B
CCL-170B-9-SS	170 L	IR	CO ₂	ULPA	90°C Moist Heat	110 - 130 V, AC, 50/60 Hz, 1Φ	Yes	L7B
CCL-170T-8	170 L	IR	CO ₂ /O ₂	ULPA	90°C Moist Heat	220 - 240 V, AC, 50/60 Hz, 1Φ	Yes	L7T
CCL-170T-8-NF	170 L	IR	CO ₂ /O ₂	N/A	90°C Moist Heat	220 - 240 V, AC, 50/60 Hz, 1Φ	Yes	L7T
CCL-170T-8-SS	170 L	IR	CO ₂ /O ₂	N/A	90°C Moist Heat	220 - 240 V, AC, 50/60 Hz, 1Φ	Yes	L7T
CCL-170T-9	170 L	IR	CO ₂ /O ₂	ULPA	90°C Moist Heat	110 - 130 V, AC, 50/60 Hz, 1Φ	Yes	L7T
CCL-170T-9-NF	170 L	IR	CO ₂ /O ₂	N/A	90°C Moist Heat	110 - 130 V, AC, 50/60 Hz, 1Φ	Yes	L7T
CCL-170T-9-SS	170 L	IR	CO ₂ /O ₂	N/A	90°C Moist Heat	110 - 130 V, AC, 50/60 Hz, 1Φ	Yes	L7T
CCL-240B-8	240 L	IR	CO ₂	ULPA	90°C Moist Heat	220 - 240 V, AC, 50/60 Hz, 1Φ	No	-
CCL-240B-8-NF	240 L	IR	CO ₂	N/A	90°C Moist Heat	220 - 240 V, AC, 50/60 Hz, 1Φ	No	-
CCL-240B-8-SS	240 L	IR	CO ₂	N/A	90°C Moist Heat	220 - 240 V, AC, 50/60 Hz, 1Φ	No	-
CCL-240B-9	240 L	IR	CO ₂	ULPA	90°C Moist Heat	110 - 130 V, AC, 50/60 Hz, 1Φ	No	-
CCL-240B-9-NF	240 L	IR	CO ₂	N/A	90°C Moist Heat	110 - 130 V, AC, 50/60 Hz, 1Φ	No	-
CCL-240B-9-SS	240 L	IR	CO ₂	N/A	90°C Moist Heat	110 - 130 V, AC, 50/60 Hz, 1Φ	No	-
CCL-240T-8	240 L	IR	CO ₂ /O ₂	ULPA	90°C Moist Heat	220 - 240 V, AC, 50/60 Hz, 1Φ	Yes	L4T
CCL-240T-8-NF	240 L	IR	CO ₂ /O ₂	N/A	90°C Moist Heat	220 - 240 V, AC, 50/60 Hz, 1Φ	Yes	L4T
CCL-240T-8-SS	240 L	IR	CO ₂ /O ₂	N/A	90°C Moist Heat	220 - 240 V, AC, 50/60 Hz, 1Φ	Yes	L4T
CCL-240T-9	240 L	IR	CO ₂ /O ₂	ULPA	90°C Moist Heat	110 - 130 V, AC, 50/60 Hz, 1Φ	Yes	L4T
CCL-240T-9-NF	240 L	IR	CO ₂ /O ₂	N/A	90°C Moist Heat	110 - 130 V, AC, 50/60 Hz, 1Φ	Yes	L4T
CCL-240T-9-SS	240 L	IR	CO ₂ /O ₂	N/A	90°C Moist Heat	110 - 130 V, AC, 50/60 Hz, 1Φ	Yes	L4T

CelCulture® CO ₂ Incubator (Stainless Steel Chamber with Flat Door)								
Model	Size	Sensor	Control	Filter	Decontamination	Electrical Rating	Water Pan Cover	
							Yes/No	Code
CCL-050B-8-FD	50 L	IR	CO ₂	N/A	90°C Moist Heat	220 - 240 V, AC, 50/60 Hz, 1Φ	Yes	B
CCL-050B-9-FD	50 L	IR	CO ₂	N/A	90°C Moist Heat	110 - 130 V, AC, 50/60 Hz, 1Φ	Yes	B
CCL-050T-8-FD	50 L	IR	CO ₂ /O ₂	N/A	90°C Moist Heat	220 - 240 V, AC, 50/60 Hz, 1Φ	Yes	T
CCL-050T-9-FD	50 L	IR	CO ₂ /O ₂	N/A	90°C Moist Heat	110 - 130 V, AC, 50/60 Hz, 1Φ	Yes	T
CCL-170B-8-FD	170 L	IR	CO ₂	ULPA	90°C Moist Heat	220 - 240 V, AC, 50/60 Hz, 1Φ	Yes	L7B
CCL-170B-9-FD	170 L	IR	CO ₂	ULPA	90°C Moist Heat	110 - 130 V, AC, 50/60 Hz, 1Φ	Yes	L7B
CCL-170T-8-FD	170 L	IR	CO ₂ /O ₂	ULPA	90°C Moist Heat	220 - 240 V, AC, 50/60 Hz, 1Φ	Yes	L7T
CCL-170T-9-FD	170 L	IR	CO ₂ /O ₂	ULPA	90°C Moist Heat	110 - 130 V, AC, 50/60 Hz, 1Φ	Yes	L7T
CCL-240B-8-FD	240 L	IR	CO ₂	ULPA	90°C Moist Heat	220 - 240 V, AC, 50/60 Hz, 1Φ	No	-
CCL-240B-9-FD	240 L	IR	CO ₂	ULPA	90°C Moist Heat	110 - 130 V, AC, 50/60 Hz, 1Φ	No	-
CCL-240T-8-FD	240 L	IR	CO ₂ /O ₂	ULPA	90°C Moist Heat	220 - 240 V, AC, 50/60 Hz, 1Φ	Yes	L4T
CCL-240T-9-FD	240 L	IR	CO ₂ /O ₂	ULPA	90°C Moist Heat	110 - 130 V, AC, 50/60 Hz, 1Φ	Yes	L4T

CelCulture® CO ₂ Incubator (for IVF Application)								
Model	Size	Sensor	Control	Filter	Decontamination	Electrical Rating	Water Pan Cover	
							Yes/No	Code
CCL-050B-8-IVF	50 L	IR	CO ₂	N/A	90°C Moist Heat	220 - 240 V, AC, 50/60 Hz, 1Φ	Yes	B
CCL-050B-9-IVF	50 L	IR	CO ₂	N/A	90°C Moist Heat	110 - 130 V, AC, 50/60 Hz, 1Φ	Yes	B
CCL-050T-8-IVF	50 L	IR	CO ₂ /O ₂	N/A	90°C Moist Heat	220 - 240 V, AC, 50/60 Hz, 1Φ	Yes	T
CCL-050T-9-IVF	50 L	IR	CO ₂ /O ₂	N/A	90°C Moist Heat	110 - 130 V, AC, 50/60 Hz, 1Φ	Yes	T
CCL-170B-8-IVF	170 L	IR	CO ₂	ULPA	90°C Moist Heat	220 - 240 V, AC, 50/60 Hz, 1Φ	Yes	L7B
CCL-170B-9-IVF	170 L	IR	CO ₂	ULPA	90°C Moist Heat	110 - 130 V, AC, 50/60 Hz, 1Φ	Yes	L7B
CCL-170T-8-IVF	170 L	IR	CO ₂ /O ₂	ULPA	90°C Moist Heat	220 - 240 V, AC, 50/60 Hz, 1Φ	Yes	L7T

CCL-170T-9-IVF	170 L	IR	CO ₂ /O ₂	ULPA	90°C Moist Heat	110 - 130 V, AC, 50/60 Hz, 1Φ	Yes	L7T
CCL-240B-8-IVF	240 L	IR	CO ₂	ULPA	90°C Moist Heat	220 - 240 V, AC, 50/60 Hz, 1Φ	No	-
CCL-240B-9-IVF	240 L	IR	CO ₂	ULPA	90°C Moist Heat	110 - 130 V, AC, 50/60 Hz, 1Φ	No	-
CCL-240T-8-IVF	240 L	IR	CO ₂ /O ₂	ULPA	90°C Moist Heat	220 - 240 V, AC, 50/60 Hz, 1Φ	Yes	L4T
CCL-240T-9-IVF	240 L	IR	CO ₂ /O ₂	ULPA	90°C Moist Heat	110 - 130 V, AC, 50/60 Hz, 1Φ	Yes	L4T
CCL-170T-9-P-IVF	170 L	IR	CO ₂ /O ₂	ULPA	90°C Moist Heat	110 - 130 V, AC, 50/60 Hz, 1Φ	Yes	L7T

CelCulture® CO ₂ Incubator (100% Copper Chamber)								
Model	Size	Sensor	Control	Filter	Decontamination	Electrical Rating	Water Pan Cover	
							Yes/No	Code
CCL-050B-8-Cu	50 L	IR	CO ₂	N/A	90°C Moist Heat	220 - 240 V, AC, 50/60 Hz, 1Φ	Yes	N/A
CCL-050B-9-Cu	50 L	IR	CO ₂	N/A	90°C Moist Heat	110 - 130 V, AC, 50/60 Hz, 1Φ	Yes	N/A
CCL-170B-8-Cu	170 L	IR	CO ₂	ULPA	90°C Moist Heat	220 - 240 V, AC, 50/60 Hz, 1Φ	Yes	N/A
CCL-170B-9-Cu	170 L	IR	CO ₂	ULPA	90°C Moist Heat	110 - 130 V, AC, 50/60 Hz, 1Φ	Yes	N/A
CCL-240B-8-Cu	240 L	IR	CO ₂	ULPA	90°C Moist Heat	220 - 240 V, AC, 50/60 Hz, 1Φ	No	-
CCL-240B-9-Cu	240 L	IR	CO ₂	ULPA	90°C Moist Heat	110 - 130 V, AC, 50/60 Hz, 1Φ	No	-
CCL-050T-8-Cu	50 L	IR	CO ₂ /O ₂	N/A	90°C Moist Heat	220 - 240 V, AC, 50/60 Hz, 1Φ	Yes	N/A
CCL-050T-9-Cu	50 L	IR	CO ₂ /O ₂	N/A	90°C Moist Heat	110 - 130 V, AC, 50/60 Hz, 1Φ	Yes	N/A
CCL-170T-8-Cu	170 L	IR	CO ₂ /O ₂	ULPA	90°C Moist Heat	220 - 240 V, AC, 50/60 Hz, 1Φ	Yes	N/A
CCL-170T-9-Cu	170 L	IR	CO ₂ /O ₂	ULPA	90°C Moist Heat	110 - 130 V, AC, 50/60 Hz, 1Φ	Yes	N/A
CCL-240T-8-Cu	240 L	IR	CO ₂ /O ₂	ULPA	90°C Moist Heat	220 - 240 V, AC, 50/60 Hz, 1Φ	Yes	N/A
CCL-240T-9-Cu	240 L	IR	CO ₂ /O ₂	ULPA	90°C Moist Heat	110 - 130 V, AC, 50/60 Hz, 1Φ	Yes	N/A

CelCulture® CO ₂ Incubator (with Peltier Cooling Mode)								
Model	Size	Sensor	Control	Filter	Decontamination	Electrical Rating	Water Pan Cover	
							Yes/No	Code
CCL-170B-8-P	170 L	IR	CO ₂	ULPA	90°C Moist Heat	220 - 240 V, AC, 50/60 Hz, 1Φ	Yes	L7B
CCL-170B-9-P	170 L	IR	CO ₂	ULPA	90°C Moist Heat	110 - 130 V, AC, 50/60 Hz, 1Φ	Yes	L7B
CCL-170T-8-P	170 L	IR	CO ₂ /O ₂	ULPA	90°C Moist Heat	220 - 240 V, AC, 50/60 Hz, 1Φ	Yes	L7T
CCL-170T-9-P	170 L	IR	CO ₂ /O ₂	ULPA	90°C Moist Heat	110 - 130 V, AC, 50/60 Hz, 1Φ	Yes	L7T
CCL-240B-8-P	240 L	IR	CO ₂	ULPA	90°C Moist Heat	220 - 240 V, AC, 50/60 Hz, 1Φ	No	-
CCL-240B-9-P	240 L	IR	CO ₂	ULPA	90°C Moist Heat	110 - 130 V, AC, 50/60 Hz, 1Φ	No	-
CCL-240T-8-P	240 L	IR	CO ₂ /O ₂	ULPA	90°C Moist Heat	220 - 240 V, AC, 50/60 Hz, 1Φ	Yes	L4T
CCL-240T-9-P	240 L	IR	CO ₂ /O ₂	ULPA	90°C Moist Heat	110 - 130 V, AC, 50/60 Hz, 1Φ	Yes	L4T

CelCulture® CO ₂ Incubator with UV Lamp (Stainless Steel Chamber with Curved Door)								
Model	Size	Sensor	Control	Filter	Decontamination	Electrical Rating	Water Pan Cover	
							Yes/No	Code
CCL-170B-8-UV	170 L	IR	CO ₂	ULPA	90°C Moist Heat	220 - 240 V, AC, 50/60 Hz, 1Φ	Yes	L7B
CCL-170B-9-UV	170 L	IR	CO ₂	ULPA	90°C Moist Heat	110 - 130 V, AC, 50/60 Hz, 1Φ	Yes	L7B
CCL-170T-8-UV	170 L	IR	CO ₂ /O ₂	ULPA	90°C Moist Heat	220 - 240 V, AC, 50/60 Hz, 1Φ	Yes	L7T
CCL-170T-9-UV	170 L	IR	CO ₂ /O ₂	ULPA	90°C Moist Heat	110 - 130 V, AC, 50/60 Hz, 1Φ	Yes	L7T
CCL-240B-8-UV	240 L	IR	CO ₂	ULPA	90°C Moist Heat	220 - 240 V, AC, 50/60 Hz, 1Φ	No	-
CCL-240B-9-UV	240 L	IR	CO ₂	ULPA	90°C Moist Heat	110 - 130 V, AC, 50/60 Hz, 1Φ	No	-
CCL-240T-8-UV	240 L	IR	CO ₂ /O ₂	ULPA	90°C Moist Heat	220 - 240 V, AC, 50/60 Hz, 1Φ	Yes	L4T
CCL-240T-9-UV	240 L	IR	CO ₂ /O ₂	ULPA	90°C Moist Heat	110 - 130 V, AC, 50/60 Hz, 1Φ	Yes	L4T

CelCulture® CO ₂ Incubator with UV Lamp (Stainless Steel Chamber with Flat Door)								
Model	Size	Sensor	Control	Filter	Decontamination	Electrical Rating	Water Pan Cover	
							Yes/No	Code
CCL-170B-8-UV-FD	170 L	IR	CO ₂	ULPA	90°C Moist Heat	220 - 240 V, AC, 50/60 Hz, 1Φ	Yes	L7B
CCL-170B-9-UV-FD	170 L	IR	CO ₂	ULPA	90°C Moist Heat	110 - 130 V, AC, 50/60 Hz, 1Φ	Yes	L7B
CCL-170T-8-UV-FD	170 L	IR	CO ₂ /O ₂	ULPA	90°C Moist Heat	220 - 240 V, AC, 50/60 Hz, 1Φ	Yes	L7T
CCL-170T-9-UV-FD	170 L	IR	CO ₂ /O ₂	ULPA	90°C Moist Heat	110 - 130 V, AC, 50/60 Hz, 1Φ	Yes	L7T
CCL-240B-8-UV-FD	240 L	IR	CO ₂	ULPA	90°C Moist Heat	220 - 240 V, AC, 50/60 Hz, 1Φ	No	-
CCL-240B-9-UV-FD	240 L	IR	CO ₂	ULPA	90°C Moist Heat	110 - 130 V, AC, 50/60 Hz, 1Φ	No	-
CCL-240T-8-UV-FD	240 L	IR	CO ₂ /O ₂	ULPA	90°C Moist Heat	220 - 240 V, AC, 50/60 Hz, 1Φ	Yes	L4T
CCL-240T-9-UV-FD	240 L	IR	CO ₂ /O ₂	ULPA	90°C Moist Heat	110 - 130 V, AC, 50/60 Hz, 1Φ	Yes	L4T

CelCulture® CO ₂ Incubator with UV Lamp (100% Copper Chamber)								
Model	Size	Sensor	Control	Filter	Decontamination	Electrical Rating	Water Pan Cover	
							Yes/No	Code
CCL-170B-8-Cu-UV	170 L	IR	CO ₂	ULPA	90°C Moist Heat	220 - 240 V, AC, 50/60 Hz, 1Φ	Yes	N/A
CCL-170B-9-Cu-UV	170 L	IR	CO ₂	ULPA	90°C Moist Heat	110 - 130 V, AC, 50/60 Hz, 1Φ	Yes	N/A
CCL-240B-8-Cu-UV	240 L	IR	CO ₂	ULPA	90°C Moist Heat	220 - 240 V, AC, 50/60 Hz, 1Φ	No	-
CCL-240B-9-Cu-UV	240 L	IR	CO ₂	ULPA	90°C Moist Heat	110 - 130 V, AC, 50/60 Hz, 1Φ	No	-
CCL-170T-8-Cu-UV	170 L	IR	CO ₂ /O ₂	ULPA	90°C Moist Heat	220 - 240 V, AC, 50/60 Hz, 1Φ	Yes	N/A

CCL-170T-9-Cu-UV	170 L	IR	CO ₂ /O ₂	ULPA	90°C Moist Heat	110 - 130 V, AC, 50/60 Hz, 1Φ	Yes	N/A
CCL-240T-8-Cu-UV	240 L	IR	CO ₂ /O ₂	ULPA	90°C Moist Heat	220 - 240 V, AC, 50/60 Hz, 1Φ	Yes	N/A
CCL-240T-9-Cu-UV	240 L	IR	CO ₂ /O ₂	ULPA	90°C Moist Heat	110 - 130 V, AC, 50/60 Hz, 1Φ	Yes	N/A

CelCulture® CO ₂ Incubator with UV Lamp (with Peltier Cooling Mode)								
Model	Size	Sensor	Control	Filter	Decontamination	Electrical Rating	Water Pan Cover	
							Yes/No	Code
CCL-170B-8-P-UV	170 L	IR	CO ₂	ULPA	90°C Moist Heat	220 - 240 V, AC, 50/60 Hz, 1Φ	Yes	L7B
CCL-170B-9-P-UV	170 L	IR	CO ₂	ULPA	90°C Moist Heat	110 - 130 V, AC, 50/60 Hz, 1Φ	Yes	L7B
CCL-170T-8-P-UV	170 L	IR	CO ₂ /O ₂	ULPA	90°C Moist Heat	220 - 240 V, AC, 50/60 Hz, 1Φ	Yes	L7T
CCL-170T-9-P-UV	170 L	IR	CO ₂ /O ₂	ULPA	90°C Moist Heat	110 - 130 V, AC, 50/60 Hz, 1Φ	Yes	L7T
CCL-240B-8-P-UV	240 L	IR	CO ₂	ULPA	90°C Moist Heat	220 - 240 V, AC, 50/60 Hz, 1Φ	No	-
CCL-240B-9-P-UV	240 L	IR	CO ₂	ULPA	90°C Moist Heat	110 - 130 V, AC, 50/60 Hz, 1Φ	No	-
CCL-240T-8-P-UV	240 L	IR	CO ₂ /O ₂	ULPA	90°C Moist Heat	220 - 240 V, AC, 50/60 Hz, 1Φ	Yes	L4T
CCL-240T-9-P-UV	240 L	IR	CO ₂ /O ₂	ULPA	90°C Moist Heat	110 - 130 V, AC, 50/60 Hz, 1Φ	Yes	L4T

CelCulture® CO ₂ Incubator with UV Lamp (with Stainless Steel Exterior)								
Model	Size	Sensor	Control	Filter	Decontamination	Electrical Rating	Water Pan Cover	
							Yes/No	Code
CCL-170B-8-UV-SS	170 L	IR	CO ₂	ULPA	90°C Moist Heat	220 - 240 V, AC, 50/60 Hz, 1Φ	Yes	L7B
CCL-170B-9-UV-SS	170 L	IR	CO ₂	ULPA	90°C Moist Heat	110 - 130 V, AC, 50/60 Hz, 1Φ	Yes	L7B
CCL-170T-8-UV-SS	170 L	IR	CO ₂ /O ₂	ULPA	90°C Moist Heat	220 - 240 V, AC, 50/60 Hz, 1Φ	Yes	L7T
CCL-170T-9-UV-SS	170 L	IR	CO ₂ /O ₂	ULPA	90°C Moist Heat	110 - 130 V, AC, 50/60 Hz, 1Φ	Yes	L7T
CCL-240B-8-UV-SS	240 L	IR	CO ₂	ULPA	90°C Moist Heat	220 - 240 V, AC, 50/60 Hz, 1Φ	No	-
CCL-240B-9-UV-SS	240 L	IR	CO ₂	ULPA	90°C Moist Heat	110 - 130 V, AC, 50/60 Hz, 1Φ	No	-
CCL-240T-8-UV-SS	240 L	IR	CO ₂ /O ₂	ULPA	90°C Moist Heat	220 - 240 V, AC, 50/60 Hz, 1Φ	Yes	L4T
CCL-240T-9-UV-SS	240 L	IR	CO ₂ /O ₂	ULPA	90°C Moist Heat	110 - 130 V, AC, 50/60 Hz, 1Φ	Yes	L4T

2. Safety Warning

- Anyone working with, on or around this equipment should read this manual. Failure to read, understand and follow the instructions given in this documentation may result in damage to the unit, injury to operating personnel and/or poor equipment performance.
- Any adjustment, modification or maintenance to this equipment must be undertaken by qualified service personnel.
- The use of any hazardous materials in this equipment must be monitored by an industrial hygienist, safety officer or some other suitably qualified individual.
- Before you proceed, you should thoroughly understand the installation procedures and take note of the environmental / electrical requirements.
- In this manual, important safety related points will be marked with the symbol .
- If the equipment is used in a manner not specified by this manual, the protection provided by this equipment may be impaired.

3. Document Management

We recommend that you keep this manual, along with the factory test report close to the equipment for easy reference by the operator and qualified maintenance personnel.

If you require replacements for any of the provided documentation (including factory test reports) you can request copies from Esco Customer Services*. Please provide the following information when making requests for replacement documents:

- Company (Organization) Name
- Product Brand and Model
- Product Serial Number
- Documents requested

* There may be a nominal charge for this service.

4. Limitation of Liability

- The disposal and / or emission of substances used in connection with this equipment may be governed by various local regulations. Familiarization and compliance with any such regulations are the sole responsibility of the users. Esco’s liability is limited with respect to user compliance with such regulations.
- The device should not be used when the environmental, location, power, gas, and water supply requirements as stated in this user manual cannot be complied with. Samples with unknown or potentially harmful compositions must not be loaded into the device. Only trained personnel shall operate the device.
- Esco Voyager® is a PC-based software package developed for the remote monitoring, data logging, and programming / device configuration of some models of Esco controlled environment laboratory equipment.

If customers want to use their own PC-based software to control Esco equipment, Esco may, at its sole discretion, after a non-disclosure agreement is executed, provide the Esco communication protocol to the customer. Under no circumstances shall Esco be responsible for integration work, or providing additional technical support, unless a special agreement is entered into separately.

5. European Union Directive on WEEE and RoHS

The European Union has issued two directives:

- **Directive 2002/96/EC on Waste Electrical and Electronic Equipment (WEEE)**

This product is required to comply with the European Union’s Waste Electrical & Electronic Equipment (WEEE) Directive 2002/96/EC. It is marked with the following symbol:

Esco sells products through distributors throughout Europe. Contact your local Esco distributor for recycling/disposal.





Recommended method of disposal is according to The Federal, State and Local Governmental regulations.

- **Directive 2002/95/EC on Restriction on the use of Hazardous Substances (RoHS)**

With respect to the directive on RoHS, please note that this CO₂ incubator falls under category 8 (medical devices) and category 9 (monitoring and control instruments) and is therefore exempted from requirement to comply with the provisions of this directive.

6. Symbols

The information and instructions in this manual may be accompanied by symbols shown in the table below. They draw the reader's attention to important information on the use, safety and maintenance of incubator.

 <p>CAUTION: Electrical Hazard Lift this panel to service the electrical, filter and blower systems. Disconnect power before electrical service.</p> <p>5150</p>	<p>Caution: Electrical Hazard Lift this panel to service the electrical, filter and blower systems. Disconnect power before electrical service.</p>
 <p>HOT SURFACE</p> <p>5137</p>	<p>Caution: Hot Surface Hot surfaces inside. Avoid contact.</p>

7. Packaging

Packaging as transportation requirement for the CO₂ Incubator is through protection by a transparent film and is immobilized by wood support. Triple layer cartons are used to secure the units and placed on a wooden pallet. The dimension of the box and the pallet will depend on the size of the CelCulture CO₂ Incubator. Outside the packaging, there are some labels to indicate the CO₂ incubator specific model, serial number, barcode, work order, PO no, SO no, customer, and the shipping details together with symbols.

After the device has been delivered, check immediately for completeness and/or possible damage. Refer to the following detailed list of items included in the packaging to verify the completeness of the product:

- (1 pc) CO₂ Incubator
- (1 pc) Test Report
- (1 pc) Cord set
- (4 pcs) Tray
- (1 pc) Water pan
- (1 set) Filtered air exchange kit + seal tape
- (1 set) Extra internal hardware kit
- (1 set) Stacking bracket kit
- (1 set) Tubing for CO₂ Injection

If components are missing or damage is found on the device or the packaging, esp. damage caused by humidity and water, please contact your freight carrier as well as the Technical Support of Esco Lifesciences immediately.

Storage requirement for the CelCulture® CO₂ Incubator:

The device may only be stored under the following conditions:

- The unit can be in storage for at least one year. If stored longer than one year, the unit must be returned to the manufacturer for a new release test.
- The unit can be stored at temperatures between -20°C and + 50°C.
- Keep away from direct sunlight.
- Do not use it if the packing material is damaged and report immediately.
- Keep dry.

Esco is not liable for any damage incurred on the objects used on or stored in Esco equipment. If the objects are highly valuable, the use of a completely independent backup system and a 24-hr redundant monitoring system with alarm capability are recommended.

Chapter 1 - Product Information

1.1. Intended Purpose

- *When used as a medical device (Singapore only; CCL-170B-8 and CCL-_-_-IVF only)*

Esco CelCulture® CO₂ Incubator is intended to provide a controlled environment by controlling physical parameters such as the temperature, humidity, and CO₂ and O₂ gas concentration levels for the growth and development of cells, tissues, and fertilised oocytes to the blastocyst stage during IVF/ART treatments. The device can also be used for cell biology, microbiology and molecular biology, tissue engineering, neuroscience, cancer research, and other cell research.

- *When used as a general laboratory equipment (The rest of the world)*

Esco CelCulture® CO₂ Incubator is a device to provide a controlled environment in the chamber for the growth of cells by varying temperature, CO₂ level, humidity, or O₂ level by injecting N₂ gas. The device is to be used in institutions such as research centre and laboratories which involves incubation of cell lines in their activities to achieve their research goals.

1.2. Product Description

Esco CelCulture® CO₂ Incubator is designed for high-quality incubation performance through the precise control of heating and gas injections combined with multiple contamination control and ergonomic features appropriate for safe incubation of many types of cells, tissues, and similar.

The external body of CelCulture® is electro-galvanized steel coated with silver-ion impregnated Isocide™ antimicrobial powder coating which kills 99.9% of surface contaminants within 24 hours of exposure. The incubator chamber is stainless steel type 304 with rounded corners for easy cleaning. Its perforated shelves, shelves system, plenums and water pan are also made of shiny stainless steel. Interior components are easily removed without using any tools. The inner door with tight gasket seal is heated to prevent condensation.

Heater foils directly mounted on the outer surfaces of the inner chamber helps maintain a relatively uniform temperature with fast recovery time after door opening. A high-density insulation completely protects the heating elements. It is then surrounded by an air jacket which separates the chamber from the varying ambient parameters. The unit is equipped with a drift-free, non-dispersive infrared sensor which has temperature and pressure compensating feature for longer-lasting reliability. For models with suppressed O₂ control, the unit is equipped with a highly accurate zirconia O₂ sensor with non-depleting technology for longer lasting reliability. Forced convection design accelerates humidification via water pan to prevent desiccation of cell samples. An ULPA filtration system, which is 99.999% efficient at 0.1 μ to 0.2 μ particulates, is connected to the blower to ensure proper circulation of an ISO Class 5 clean air standard without affecting cell growth negatively. It is attached to a blower fan to ensure proper circulation of clean air and equal distribution of heat and gas at any point in the incubator chamber.

Given the precise measurement and control of temperature and CO₂ level, as well as the multiple contamination control methods of CelCulture® CO₂ incubator, it is especially suitable for growing mammalian cells at 37°C and in the presence of 5% CO₂.

1.3. Labels

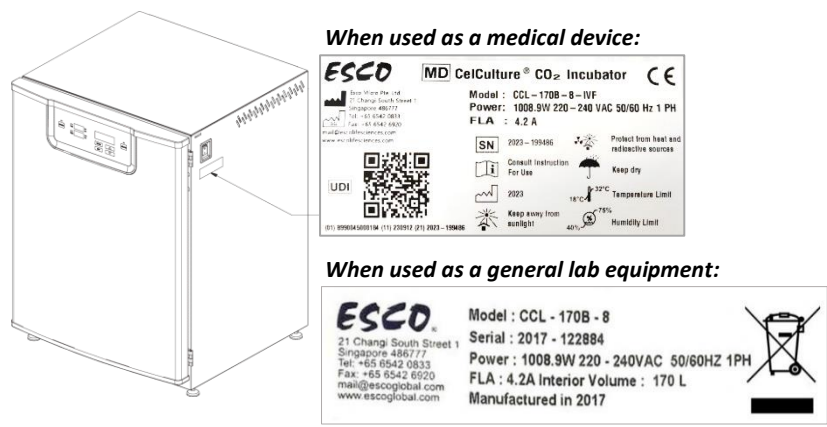

1.4. Quick View

1.4.1. Front Quick View (CCL-050_--)

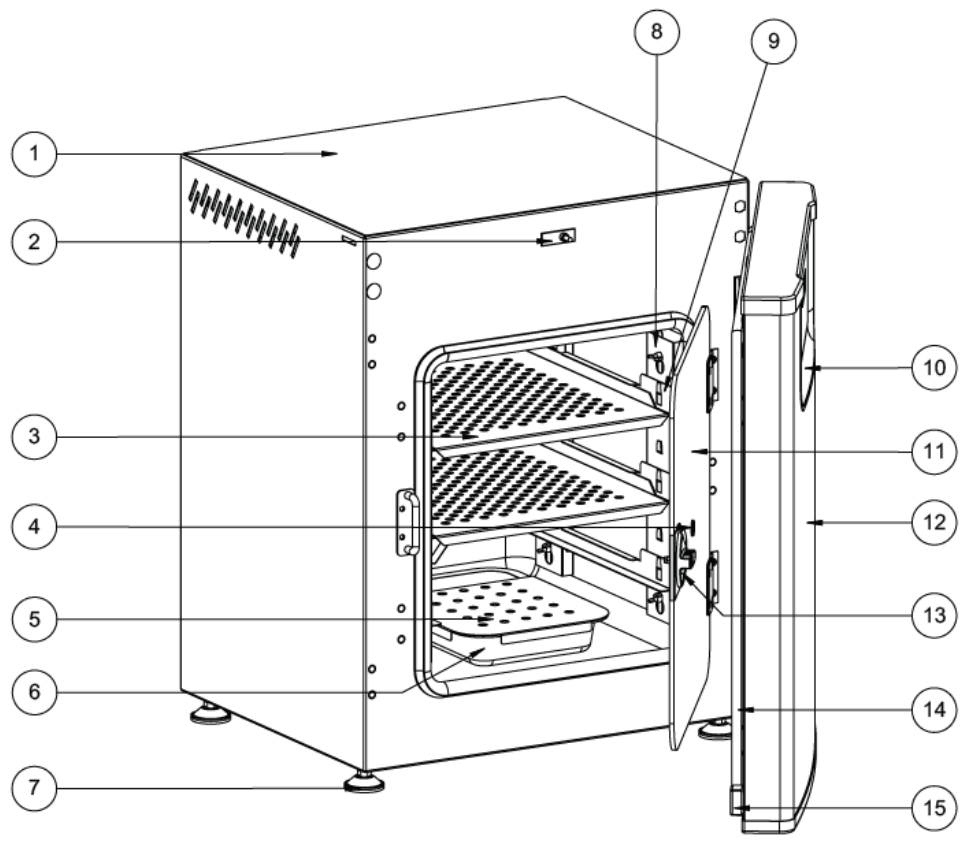

- | | |
|---------------------------|-----------------------------|
| 1. Electrical panel cover | 9. Shelving rails |
| 2. Door switch | 10. Control panel |
| 3. Shelves | 11. Inner glass door* |
| 4. Sampling port | 12. Outer door |
| 5. Water pan cover | 13. Inner glass door latch |
| 6. Water pan | 14. Inner glass door gasket |
| 7. Leveling feet | 15. Magnetic block |
| 8. Shelving bracket | |

*CCL-050_--IVF units have 2 sealed inner glass doors

1.4.2. Front Quick View (CCL-170_--_, CCL-240_--_)

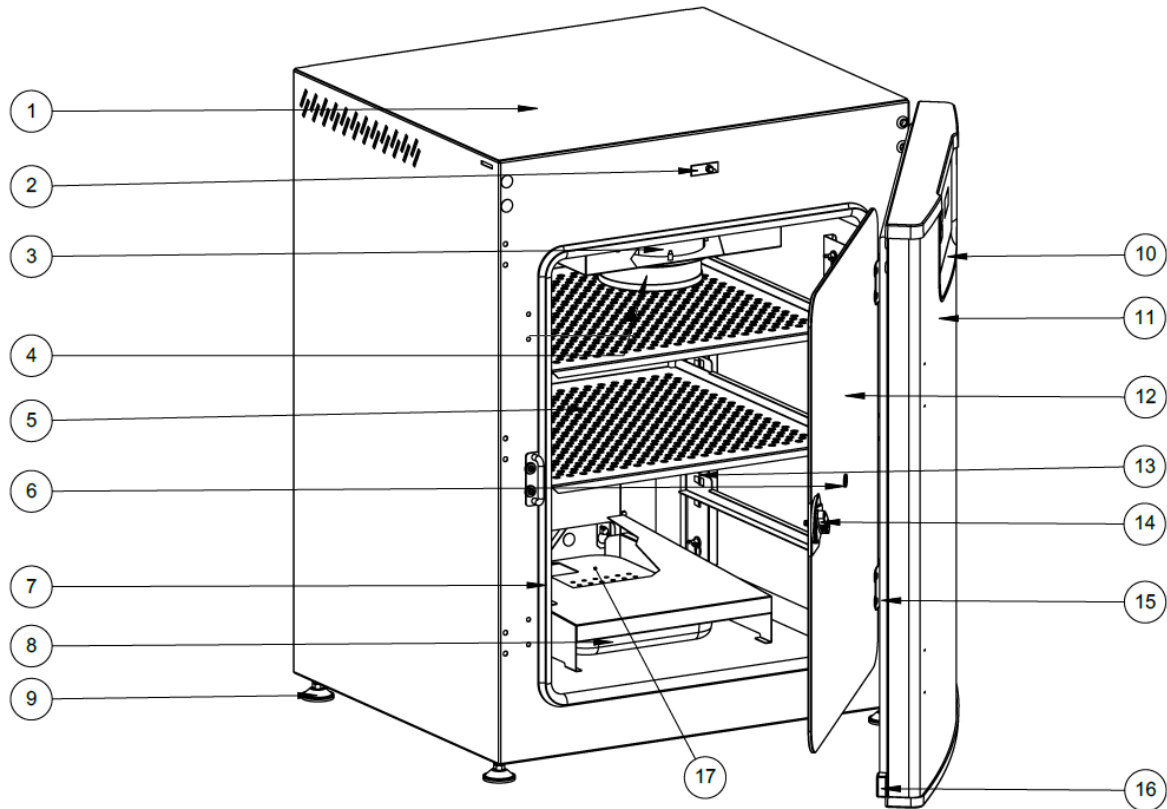

- | | |
|------------------------------------|----------------------------|
| 1. Electrical panel cover | 10. Control panel |
| 2. Door switch | 11. Outer door |
| 3. Top plenum with circulation fan | 12. Inner glass door* |
| 4. ULPA filter | 13. Pilaster shelf support |
| 5. Shelf | 14. Inner glass door latch |
| 6. Sampling port | 15. Magnetic gasket |
| 7. Inner glass door gasket | 16. Magnetic block |
| 8. Water pan | 17. Water pan cover |
| 9. Leveling feet | |

**CCL-170_--_ -IVF units have 4 sealed inner glass doors
CCL-240_--_ -IVF units have 4 or 6 sealed inner glass doors*

1.4.3. Front Quick View (CCL-170_-_-UV, CCL-170_-_-P-UV, CCL-240_-_-UV, CCL-240_-_-P-UV)

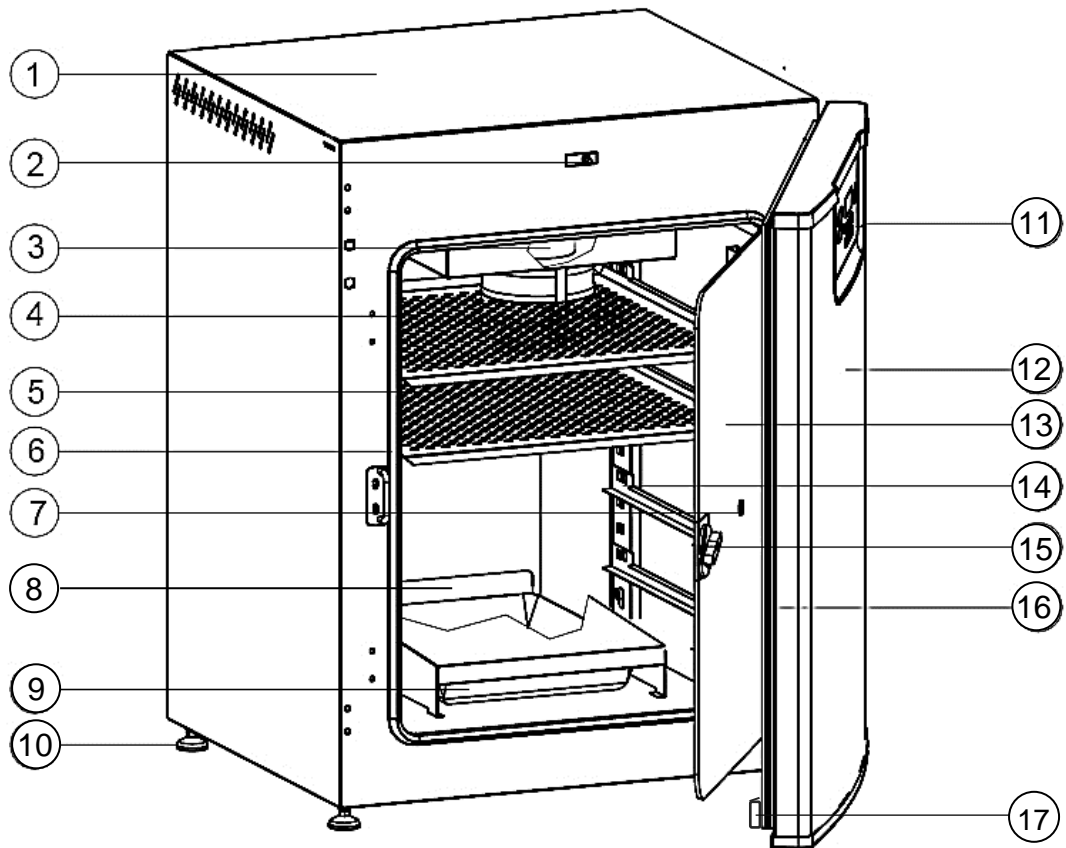

- | | |
|------------------------------------|----------------------------|
| 1. Electrical panel cover | 10. Leveling feet |
| 2. Door switch | 11. Control panel |
| 3. Top plenum with circulation fan | 12. Outer door |
| 4. ULPA filter | 13. Inner glass door |
| 5. Shelf | 14. Pilaster shelf support |
| 6. Inner glass door gasket | 15. Inner glass door latch |
| 7. Sampling port | 16. Magnetic gasket |
| 8. UV Lamp (for models with UV) | 17. Magnetic bloc |
| 9. Water pan | |

1.4.4. Back Quick View (CCL-050_--_, CCL-170_--_, CCL-240_--_, CCL-170_--UV, CCL-240_--UV)

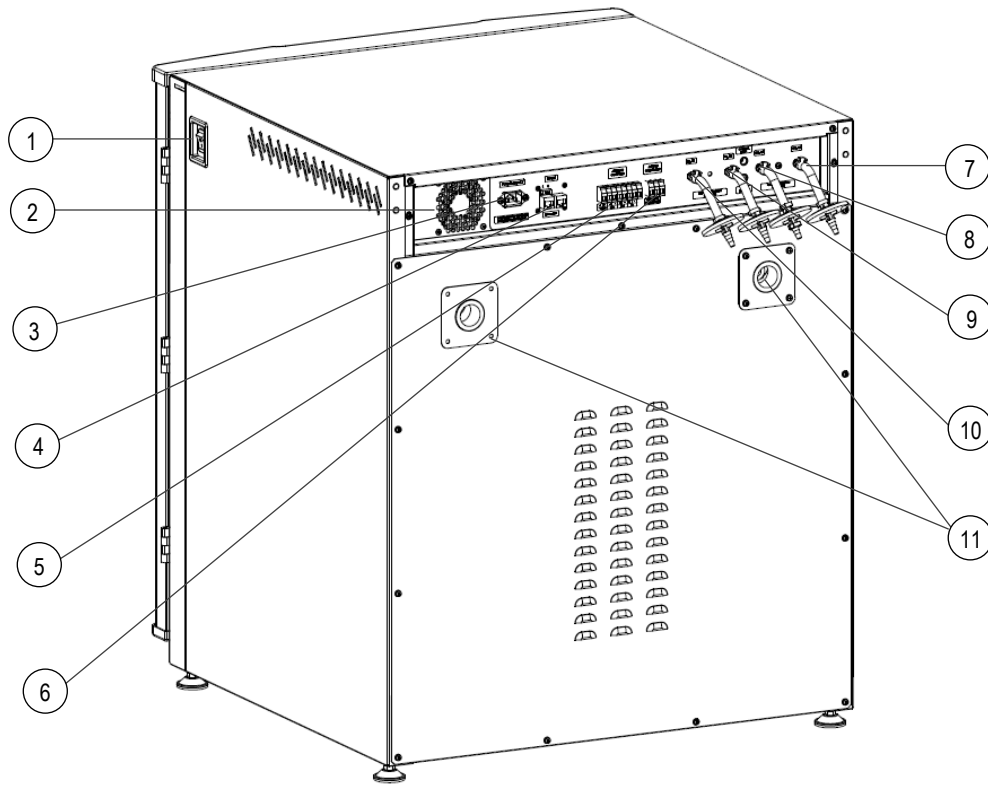

1. Power switch
2. Cooling fan*
3. Power inlet
4. RS485 communication port
5. Analog output (optional)
6. Alarm contacts
7. CO₂ gas inlet #1
8. CO₂ gas inlet #2 (for optional CO₂ backup system)
9. N₂ gas inlet #1 (for suppressed O₂ control units)
10. N₂ gas inlet #2 (for optional N₂ backup system in units with suppressed O₂ control)
11. Access ports**

**not present in 50L models*

***only 1 access port for 50L models*

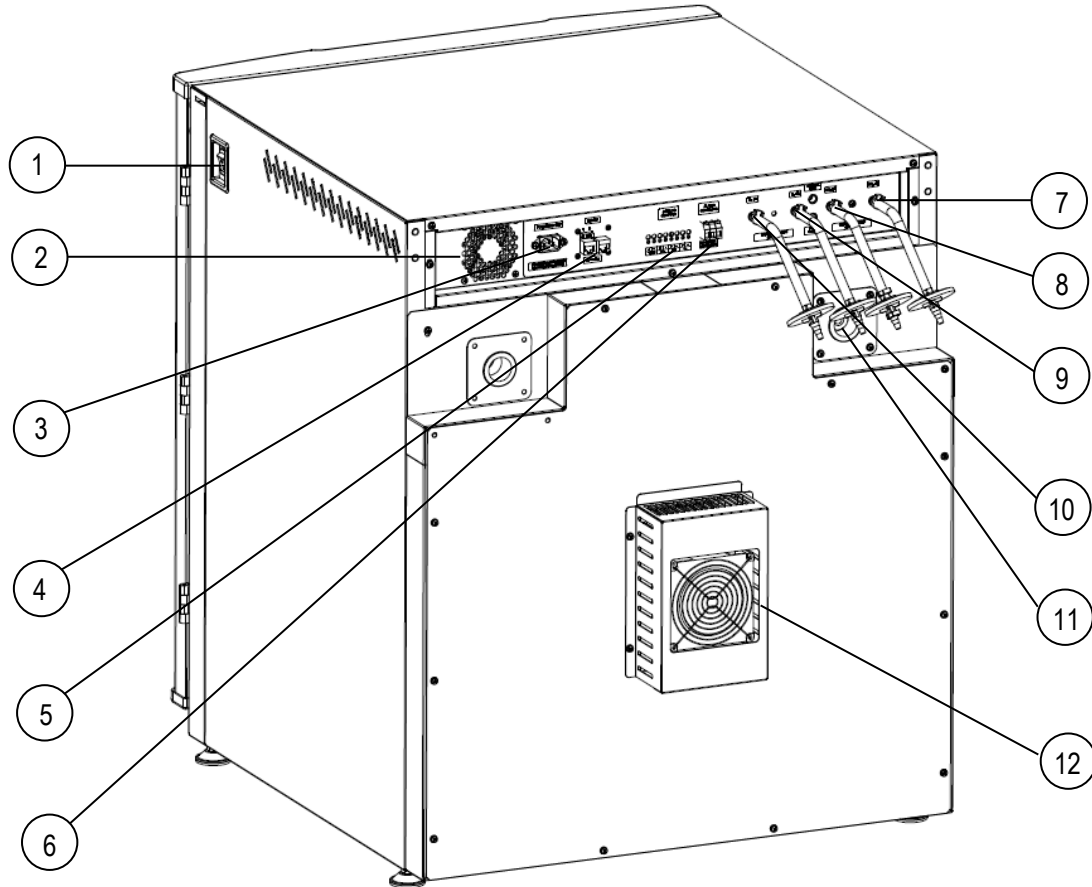
1.4.5. Back Quick View (CCL-170_--P, CCL-240_--P, CCL-170_--P-UV, CCL-240_--P-UV)

1. Power switch
2. Cooling fan
3. Power inlet
4. RS485 communication port
5. Analog output (optional)
6. Alarm contacts
7. CO₂ gas inlet #1
8. CO₂ gas inlet #2 (for optional CO₂ backup system)
9. N₂ gas inlet #1 (for suppressed O₂ control units)
10. N₂ gas inlet #2 (for optional N₂ backup system in units with suppressed O₂ control)
11. Access port
12. Peltier cooling module

Chapter 2 – Installation

2.1. General Requirements

2.1.1. Location Requirements

- The CelCulture® CO₂ Incubator should be placed on a dry, stable and sturdy working surface or on the various optionally available floor stands. It should NOT be placed directly on the floor in order to prevent condensation and the risk of contamination.
- Never place the unit close to heating or cooling ducts, flammable materials or devices that produce excess heat such as autoclaves, radiators, ovens, and similar. Do NOT install equipment outdoors, near windows, doors and other areas with rapidly moving air currents and/or direct sunlight. Installation in improper locations will greatly affect the equipment's performance.
- Before moving or relocating the unit, make sure to:
 - remove the water in the water pan to avoid spillage;
 - transfer the sample cells to another incubator; and
 - decontaminate the equipment.
- It is essential to ensure adequate air ventilation around the equipment to allow proper heat and gas dissipation, but do not place the unit directly in the path of moving air currents. It is required to allow at least 2000 mm distance between the incubator and the air conditioner or any moving current.

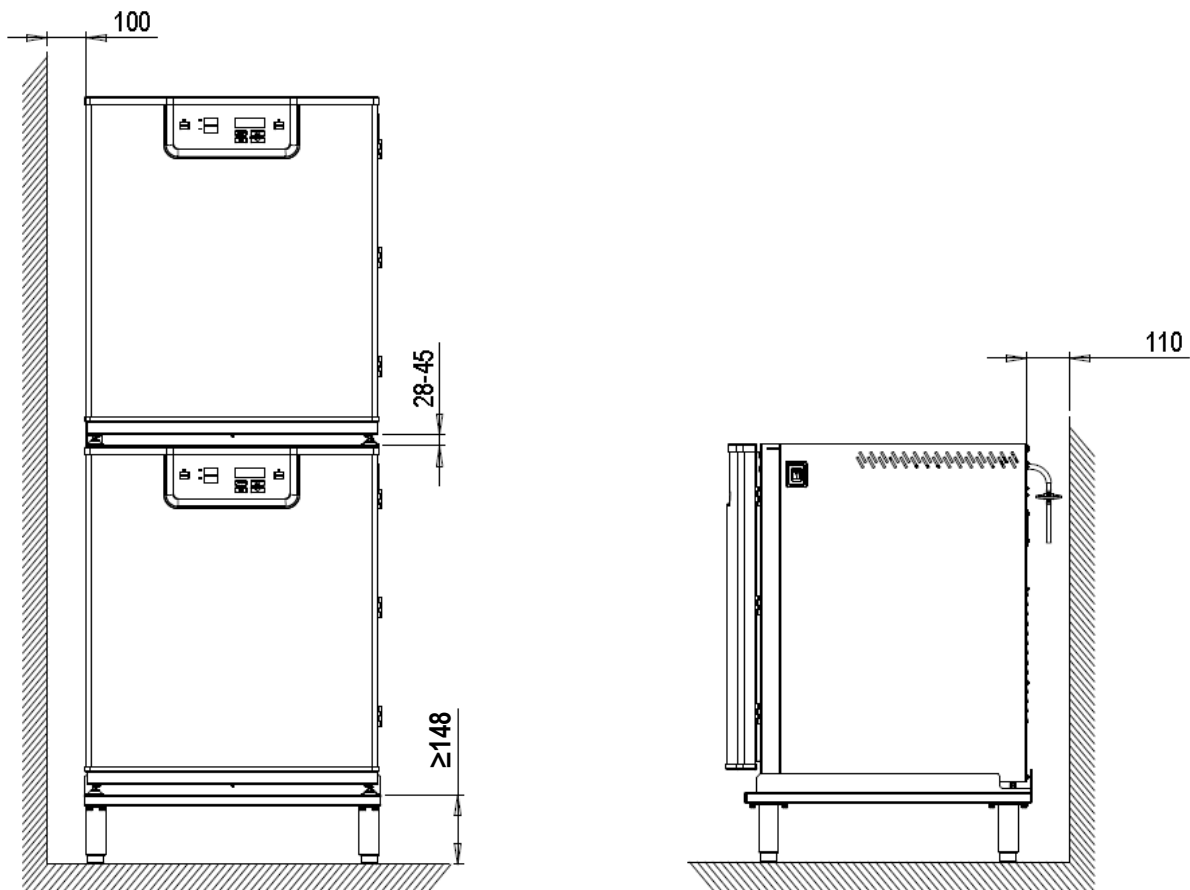

- The spacing between the unit and the side wall should be at least 100 mm (3.9”).
- The spacing at the back of the equipment should be at least 110 mm (4.3”) to allow connections to the rear panel of the equipment.
- The spacing from the floor must be ≥ 148 mm (5.8”). Never place equipment directly on the floor. It is recommended to use the optionally available floor stand to elevate the unit from the floor.

2.1.1.1. Relocating the Unit



Normally, units are rarely moved once they are in their ideal positions, but should there be a need to relocate or repackage the unit, here are some considerations:

- It is recommended that risk assessment is carried out before the unit is moved.
- Before moving the unit, remember to decontaminate the incubator.
- Before moving the unit, remember to secure all moving parts (e.g. glass door) and remove the water in the water pan to avoid spillage.
- Make sure to transfer all sample cells to another incubator.
- Unit is heavy so please carry out adequate workplace safety assessment before moving the incubator. Do not lift using the door or door handle.
- Should only manpower is available (i.e. no suitable equipment), it will usually take 6 or more people to move a unit manually.
- In relocating the unit through an elevated surface, ensure that the unit is held securely, and should face the ramp side up, as shown below:

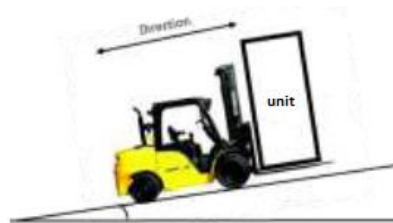

For repackaging:

- Place the unit on the pallet.
- Strap the unit body down to the pallet.
- Repackage as necessary. If possible, use original packaging.
- When moving the unit, use material handling equipment and lift the pallet.

2.1.2. Environmental Requirements

Location	Indoor use only
Altitude limit	2000 m (6600 ft.)
Ambient humidity	40% - 75% relative humidity (non-condensing) <i>Note: For optimum performance, room humidity must be 60%.</i>
Ambient temperature	18°C - 32°C (64.4°F – 89.6°F) <i>Note: For optimum performance, room temperature must be constantly at 20°C - 24°C (68°F – 75°F). If ambient temperature is not in the range of 20°C - 24°C, the temperature of the unit must be calibrated.</i>
Ventilation	ZH 1/119 (Guidelines for laboratories)
Overvoltage category	II in accordance to IEC 61010-1
Pollution degree	2.0 <i>Note: In pollution degree 2.0, it is assumed that only non-conductive pollutants such as dust are present, except when occasional conductivity caused by condensation.</i>

2.1.3. Power Requirements

- The equipment is designed to work with an electrical supply of 220 VAC – 240 VAC, 50/60 Hz or 110 VAC – 130 VAC, 50/60 Hz. If your available electrical supply is not within these parameters, a suitable power supply must be used, otherwise damage may be caused to the unit or a hazardous situation may occur.
- It is recommended that the equipment is connected to a dedicated power source with protective grounding installed.

- There should be unobstructed access to the main power plug. The power plug is the main disconnecting device on the unit.
- This equipment can sustain a maximum of $\pm 10\%$ nominal voltage fluctuation; otherwise a power stabilizer is needed.
- The cable length must be shorter than 3 meters.

2.2. Installation

2.2.1. Unit Leveling

It is important that the equipment is properly leveled by positioning rectangular water pass on each shelf of the incubator by diagonal measurement. The incubator has built-in leveling feet that can be adjusted to level the unit. Adjust the feet until the unit sits level left to right and front to back.

2.2.2. Unit Stacking

If the equipment is to be stacked on top of each other, it is advisable to use a floor stand with leveling feet or a two units floor stand, and the unit with the lower working temperature must always be placed at the bottom.

1. Remove the screws from the back at top left and top right of the lower incubator. These screws will be used to secure the stacking brackets later.
2. Position a rectangular water pass on the center top shelf of the incubator and adjust the leveling feet of the lower incubator until the incubator is level.
3. Lift the upper incubator onto the top the lower incubator and align them.

Note: Adequate care must be done when lifting the incubator. It usually takes 6 people to lift the incubator if only manpower is available. The leveling feet are NOT to be removed. They can be adjusted to allow 28 mm to 45 mm (1.1" to 1.8") clearance between the incubators.

4. There are 4 stacking brackets provided in the accessory kit box, 2 for the front and 2 for the back. Secure the stacking brackets to the unit using the M4 screw provided (see illustration).
5. Tighten the nut on the foot to secure the stacking brackets.

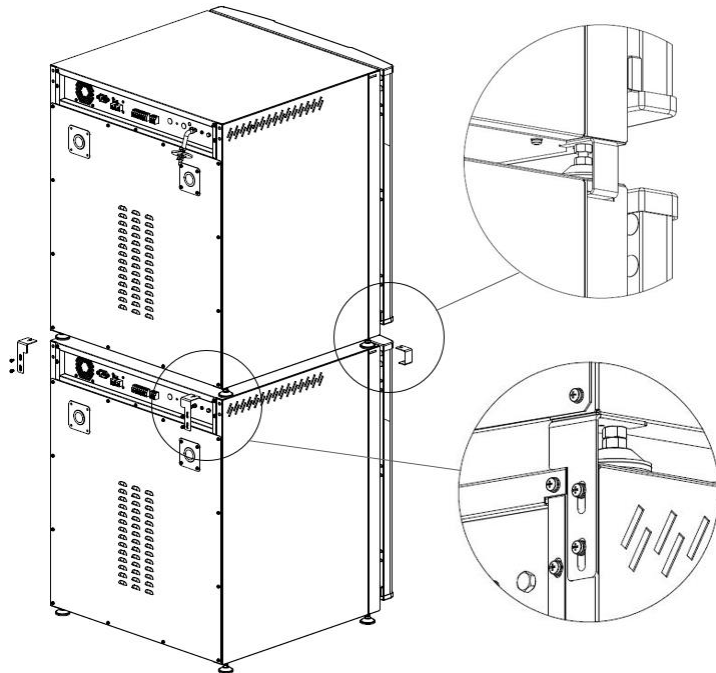

2.2.3. ULPA Filter Installation (For 170L & 240L)

To install the ULPA filter, push it into the ULPA gasket and fit it to related mounting holes and mount the ULPA filter to the top duct using thumb screws. Finally, connect the filter air exchange tubing to the ULPA filter (see illustration below).

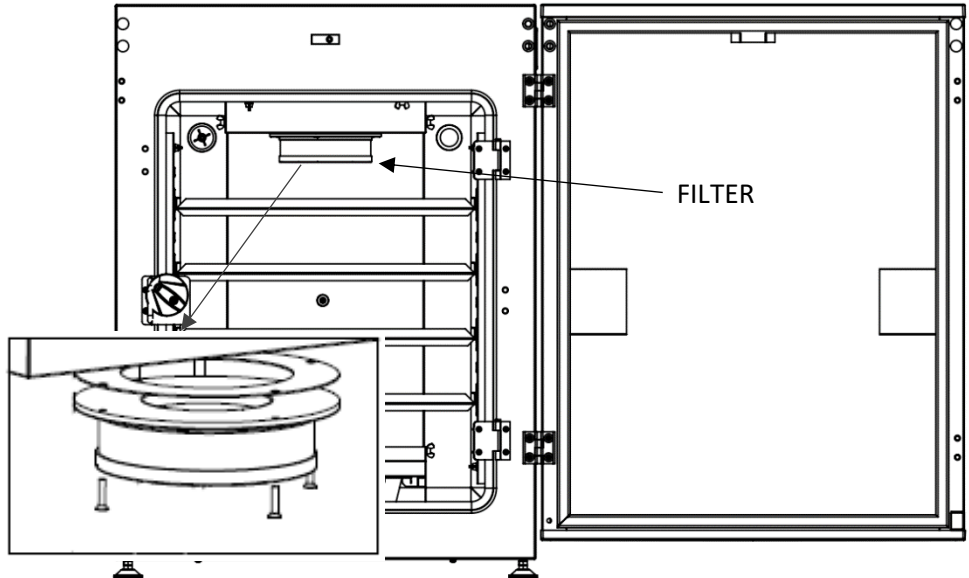

Model: CCL-170/240 _ _

Models without filter have sparger installed on the top plenum. The sparger can be kept inside the chamber during the sterilization cycle. To remove the sparger for manual disinfection, loosen the screws that secure it to the top plenum (see below illustration). Remove the tubing attached to it and pull it out from the chamber.

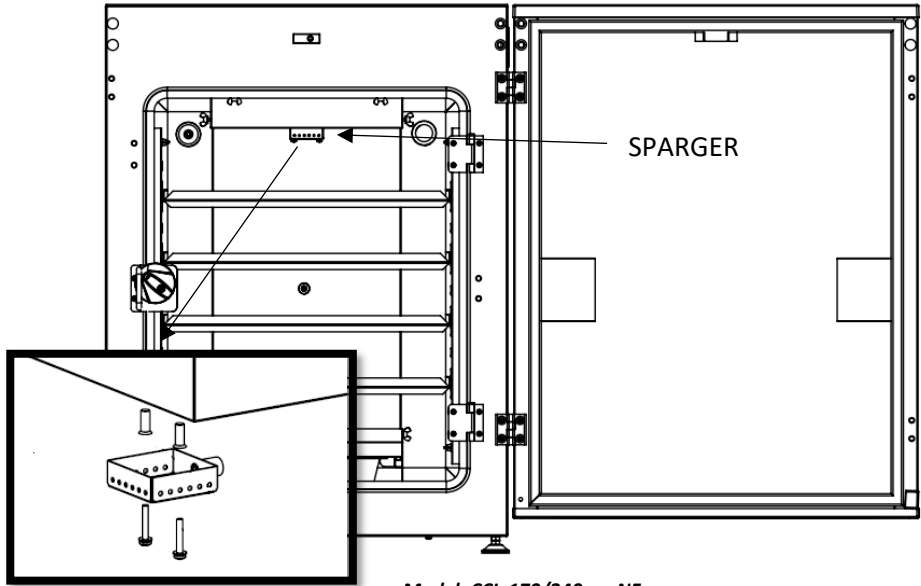

Model: CCL-170/240 _ _-NF

2.3.3.1. Installing ULPA Filter from Old to Latest Configuration

Old ULPA filter configurations such as the collared and bracketed mounting types are now phased-out due to issues encountered. Operators must check their units and change the ULPA filter mounting type to the latest type (direct mounting) if their unit is still using any of the old types. Units without ULPA filter (CCL-NF, 170 L and 240 L models only) can also be added with an ULPA filter with the latest mounting type. Refer to the table below for the conversion kit needed when upgrading to the latest filter design.

Design Type	CO ₂ Incubator Volume (L)	Part number of conversion kit needed for the upgrade	Components of conversion kit
1. Collared mounting Type and No Filter Type design (-NF)	CCL-170_ _	5071089	ULPA filter (1250081), gasket (1051440), stainless steel top plenum
		5072101 (new simplified kit)	ULPA filter (1250081), 1 x SS adaptor bracket, 2 x gasket (1051440)
		5170989	2018 NEW SIMPLIFIED KIT (5072101) + 2x Inline filter (1050771)
	CCL-240_ _	5071144	ULPA filter (1250081), gasket (1051440), stainless steel top plenum
		5072101 (new simplified kit)	ULPA filter (1250081), 1 x SS adaptor bracket, 2 x gasket (1051440)
		5170989	2018 NEW SIMPLIFIED KIT (5072101) + 2x Inline filter (1050771)
2. Bracketed mounting	CCL-170_ _	Gasket: 1051440 Filter: 1250081	No need for any kit
		5170990	1x Filter (1250081) + 1x Gasket (1051440) + 2x Inline filter (1050771)
	CCL-240_ _	Gasket: 1051440 Filter: 1250081	No need for any kit
		5170990	1x Filter (1250081) + 1x Gasket (1051440) + 2x Inline filter (1050771)
3. Direct Mounting Type	CCL-170_ _	Filter: 1250081 <i>Note: The Gasket (1051440) is just required to order if it is damage.</i>	No need for any kit
		5170992	1x Filter (1250081) + 2x Inline filter (1050771)
	CCL-240_ _	Filter: 1250081 <i>Note: The Gasket (1051440) is just required to order if it is damage.</i>	No need for any kit
		5170992	1x Filter (1250081) + 2x Inline filter (1050771)

To install the new simplified conversion kit

1. Prepare the simplified conversion kit.
2. Put gasket on the SS adaptor bracket matching the holes of both components.
3. Install the SS adaptor bracket with gasket to the old top plenum with the gasket facing the top plenum. Ensure that the two small holes at the center area of the adaptor bracket matched the holes on the top plenum.
4. Secure the SS adaptor bracket to the top plenum with 2 pcs. of screws on the 2 holes at the center area.
5. Install the other gasket to the SS adaptor bracket, still matching the 4 holes at the edges of the bracket and gasket.

6. Install the ULPA filter to the top plenum following the holes of the gasket (with the hollow side facing the gasket).
7. Tighten the ULPA filter with 4pcs. of lock nut at the holes on the rim of the filter.

2.2.4. Shelves System Installation

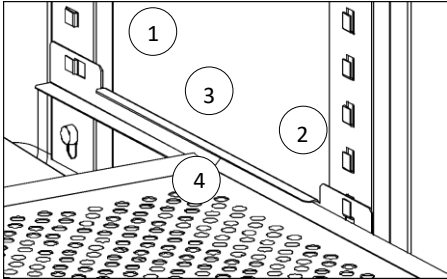

Pilasters are held against the chamber walls using thumb screws. There are 2 pilaster models – the shelf railing holders in the front pilasters (2) is open upward, while the one in the back pilasters (1) are open toward the back of the unit.

Shelf railings (3) are installed by sliding them in the shelf railing holders in the back pilaster, then the front.

Slide in the shelves (4) in the openings of the shelf railings.

2.2.5. Connecting the Unit to Electrical Power

Plug the provided power cord to the power inlet at the rear of the unit. Connect the power cord to the building outlet and turn ON the power switch of the outlet if necessary.



Note: Refer to the serial number tag located on the right side of the unit for electrical specification. Ensure the unit is connected to the correct power source.

2.2.6. Connecting the Unit to CO₂ and N₂ Gas Supply

CO₂ gas supply cylinder and N₂ gas supply cylinder (for suppressed O₂ model) should be industrial grade 99.5% pure for CO₂ and 99.995% for N₂ and without siphon tube. Install a 2-stage pressure regulator to the tank outlet. The inlet pressure must be regulated to 15 psig (103.4 kPa).

- Use the Connection Hose Kit provided in the Accessories Kit Box. A 0.2 micron inlet filter (1) is provided to remove any contaminant in the CO₂ gas supply. Check all fittings for leaks.
- Connect one end of the tubing to the barb fitting at the rear of the unit labeled CO₂ Inlet #1 and install the clamp (2) to properly secure the tubing. For Suppressed O₂ model, connect another tube to the N₂ Inlet #1.
- Connect the other end of the tubing to the outlet of the 2-stage pressure regulator and install the clamp (2).

Note: Make sure that the pressure in the two stage gas is regulated to 15 psig or 103.4 kPa.

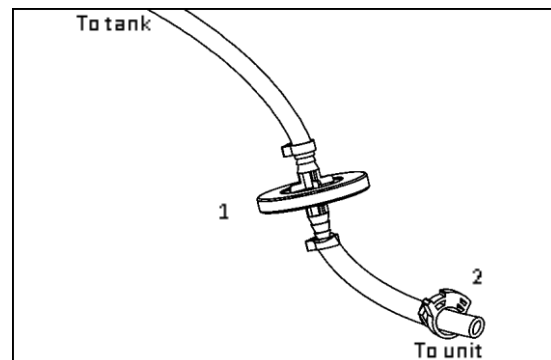

If unit is equipped with the optional built-in gas backup system, there will be 2 gas inlets. Each of the inlet should be connected to individual gas tanks as described above.



Note: Consult your facility safety officer to ensure that the equipment is installed in accordance to your local regulations and code.



Caution: Avoid contact with CO₂ gas to eyes and skin. CO₂ and N₂ gases can have a suffocating effect in high concentrations. During normal operations, small amounts of CO₂ and O₂ are released by the incubator to its surroundings. Ensure that the room is well-ventilated to prevent suffocation of operators.

2.2.7. Connecting Alarm Contacts and RS485 Communication Port

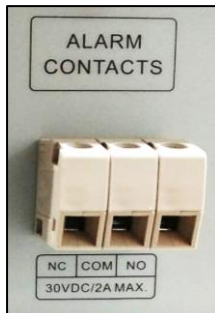

A set of relay contacts located on the rear of the unit is provided to monitor for temperature, humidity, O₂ or CO₂ alarms. The terminals provided on the alarm contact allow for a NO (normally open) output, a NC (normally closed) and COM (common) connection. In the event of an alarm condition, the NO contact will close, and the NC contact will open. Once the alarm is cleared, the contacts return to their normal condition.

To activate this function, see **section 3.3.12. Relay Activation.**

The RS485 provides serial communication port for PC. It can be daisy chained from product to product and connected to PC with Esco Voyager® Software. In connecting to RS485 communication port, it is advised to use a CAT 5E outdoor shielded network cable and internal resistance not greater than 1.5 ohms/10m (1.5 ohms/32.81 ft), as well as a cable plug, which is not supplied with the unit.



2.2.8. Connecting Esco Voyager® Software

RS485 cable and converter are to be used to connect the unit to a PC installed with Esco Voyager® Software. The maximum distance between unit should be 100 m (328 ft), while the maximum distance between the PC to the last unit should be 1000 m (3280 ft). To run the software, it is important that the minimum system requirements are met.

- Operation system: 32-bit or 64-bit Windows 2000, 2003 Server, XP, 7 Pro, 10 Pro, and 11 Pro
- Memory: 4 GB
- Hard disk space: 10 GB
- Interface: USB/RS232/RS485
- Prerequisite Software:
 - .NET framework 2.0 (included)
 - .NET framework 3.1 (included)
 - .NET framework 3.5 (included)
 - .NET framework 4.0 (included)
 - Windows Installer 3.1 (included)

Note: Internet connection required for email alert feature

2.3. Preliminary Cleaning

- Remove the tartan tape and the plastic protective coating on the shelf supports and air duct if present.
- Use a suitable laboratory disinfectant to disinfect all interior surfaces prior to using the product. It is recommended to use soft cloth with alcohol to remove adhesive residues.



Note: Please remove the adhesives (tape, covering, etc.) before performing the automated decontamination cycle. Failure to do so will result to burnt marks or stains in the shelves and chamber.



Note: Metal surfaces can be cleaned using stainless steel cleaning agents. The inner glass door surfaces can be cleaned using glass cleaners. Never use chlorine-based disinfectants. Do NOT spray disinfectant directly on the control panel and on the holes for the electrical panel on the top-side of the unit.

- See **section 5.1 Cleaning Procedure** for more information on cleaning the unit.

2.4. Filling the Water pan

During normal operations, the water pan must be filled with the respective volume of water:

Size	Normal (ml)
CCL-050L	400
CCL-170L	800
CCL-240L	800

For best operation and longevity of the incubator, sterile distilled water should only be used to fill the water pan. Never fill the pan with more than the indicated maximum level.



Note: Chlorinated tap water should not be used as chlorine can deteriorate the stainless steel. Tap water may also have a high mineral content, which would produce a build-up of scale in the water pan. Water should always be sterilized or treated with a decontaminant, safe for use with stainless steel as well as safe for the product, prior to being introduced into the water pan. If sensitive cells are being cultured, do not add decontaminant in the water.

Place the pan directly on the incubator floor to ensure optimum humidity and temperature response. **The pan needs to be inserted completely into the back of the incubator so that condensed water can drip back into the pan and avoid flooding the bottom of the chamber.** Ensure that no water is spilled on the bottom of the chamber as this will potentially lead to condensation.

- If water pan is filled with more than the indicated maximum level and / or not pushed to the back surface of the chamber, condensation will occur.
- It is recommended to check the water level and refill the water pan once a week.
- For 170/240L Suppressed O₂ model, ensure that the sparger is fully immersed in water.
- Please ensure installing the water pan cover to prevent condensation inside the chamber (for 50L models produced after March 2023, and for 170/240L models produced after June 2023).
- Make sure the water pan cover is installed correctly according to the models. Refer to **Section 1. Products Covered** for the water pan cover code.

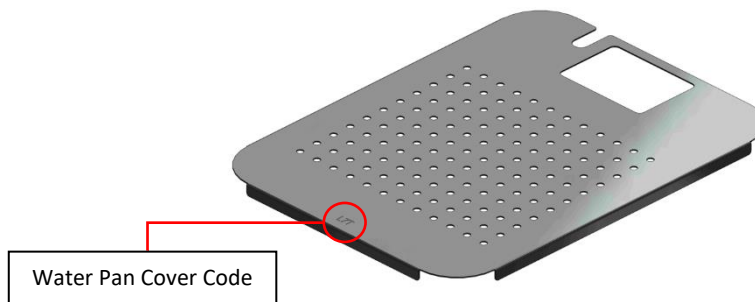

Note: This is particularly important when multiple models of Esco CO₂ Incubators are installed in your lab. Installing the water pan cover incorrectly may result in condensation.



When the incubator is turned off and will not be used for a period of time, empty the water pan and dry it before putting it back inside the unit. Leaving the water pan with water when unit is powered off will cause condensation to form in the chamber which will damage the sensors.

2.5. Filtered Air Exchange (For 170L & 240L)

Filtered air exchange is an intentional 'leak' in the chamber to reduce the relative humidity to an acceptable level (85-90%) and to ensure no condensation occurs within the chamber. A small amount of ambient air is being drawn from outside of the incubator by the re-circulating fan, through a tubing and 1 µm filter to prevent contamination in the chamber. Air is being 'pushed out' through another tubing and 1 µm filter installed on the access port plug located at the back of incubator. Tubing installed inside the chamber for filtered air exchange is silicon tubing which can withstand high decontamination temperature.

If high humidity level is required, the filtered air exchange can be removed and “Elevated Humidity” can be activated in the control panel (call Esco or your distributor to activate this function).

When set to elevated humidity mode, the incubator may be able to achieve up to 85%-90% relative humidity depending on the humidity level that the unit can achieve in default humidity mode (usually +2-3% of value from default humidity).

2.6. Use of Additional Devices in the CO₂ Incubator

Placing heat-generating electrical devices in the chamber might affect the incubator’s performance. The unit must be recalibrated or revalidated by a trained service personnel based on this application.

Use only the sampling port or the rear access port(s) for tubing or cable access. Never route any cable or tubing through the door opening as it will disrupt the environment of the chamber.

2.7. First Run

After the incubator has been properly installed, connected to the power supply, water pan filled, water pan cover is set, and the unit connected to the gas supply, set the pressure inlet to the incubator at the range of 15-17 psi. Recommended pressure is 15.5 -16 psi depending on the length of the tube from the gas tank to the incubator.

Follow the procedures for the unit’s initial start-up.

1. Switch ON the unit. A welcome message will appear on the display. Press SET to continue.
2. Keypad operation will appear on the display. Press SET to continue.
3. Set the date, time, temperature set point, %CO₂ set point and %O₂ set point:
 - a. Set Date. The digit will blink. Use UP/DOWN buttons to select the current date and press SET to confirm each digit.
 - b. Set Time. The digit will blink. Use UP/DOWN buttons to select the current time and press SET to confirm each digit.
 - c. Set Temperature Set Point. Use UP/DOWN buttons to select the temperature set point. Press SET to confirm.
 - d. Set %CO₂ Set Point. Use UP/DOWN buttons to select the %CO₂ set point. Press SET to confirm.
 - e. Set %O₂ Set Point. Use UP/DOWN buttons to select the %O₂ set point. Press SET to confirm.
(For suppressed O₂ model only)
4. Incubator set-up is done.
5. The unit will run a memory check.
6. The incubator will do an initial start-up and will continue to the main menu.

The outer door has a magnetic closure, which can be opened by pulling on the rim of the door. The inner glass door has a tight gasket seal, which prevents the chamber from being contaminated and the chamber environment from being disturbed.

When the outer door is opened the blower fan, heating, and gas injection will automatically turn off.



Note: Make sure that the door switch will not be overridden or controlled manually or by any means when the outer door is opened. During normal operations, never leave the door open as it will cause the incubator to overheat and may pose a fire hazard.

Allow 2 hours for the incubator to stabilize before loading the unit with samples or before proceeding to calibration.



Note: When loading the unit, ensure proper spacing between the samples to allow uniform air circulation inside the chamber. Never place any item touching the side walls of the incubator as it may take a longer time to reach the set temperature. For your safety, never load samples with unknown or potentially harmful composition.

2.8. UV Lamp Functionality (For CCL-UV units)

The UV lamp is located at the bottom rear part of the chamber. The main function of the UV lamp is to sterilize the water in the water pan and the air circulating in the chamber.

Always use the water pan and base plenum to prevent UV light from escaping.

To check whether the UV lamp is lit, activate the test mode by pressing up, up and set button simultaneously. Activate it by switching the UV to ON mode. Open the outer door and then press the door switch with the inner glass door closed. The appearance of visible blue light from the front of the base plenum confirms that the UV lamp is lit.



Caution: Radiation Hazard

UV functionality check must be conducted within less than 10 seconds to ensure zero risk of UV radiation. UV light is harmful to the eyes, so do not light the UV lamp when the inner door or humidifying pan cover is open.

2.9. Replacing Old CO₂ Sensor to the Latest IR Sensor

The TC sensor (which is less reliable) and the previous IR CO₂ sensor (which uses board, cable, and probe) of Esco CelCulture® CO₂ incubators are now phased out. Upgrading to the new IR CO₂ sensor (which is a stand-alone sensor) is recommended to improve the reliability and ease of handling of the sensor. Contact your local distributor for the upgrade kit to the new IR sensor (item number 1250105).



Note: Replacement of the old sensor with the new one must only be undertaken by qualified service personnel to prevent damage to the equipment.

2.10. Disclaimer

Each of the Esco units is subjected to an in-depth inspection prior to delivery. Signs of use caused by tests are possible and have no influence on the performance and function of the units.

The performance and safety of the incubator, while rigorously evaluated at the factory, cannot be guaranteed after transit and installation. Therefore, on-site testing is always recommended.

Chapter 3 - Control System and Operation

3.1. CelCulture® Control System

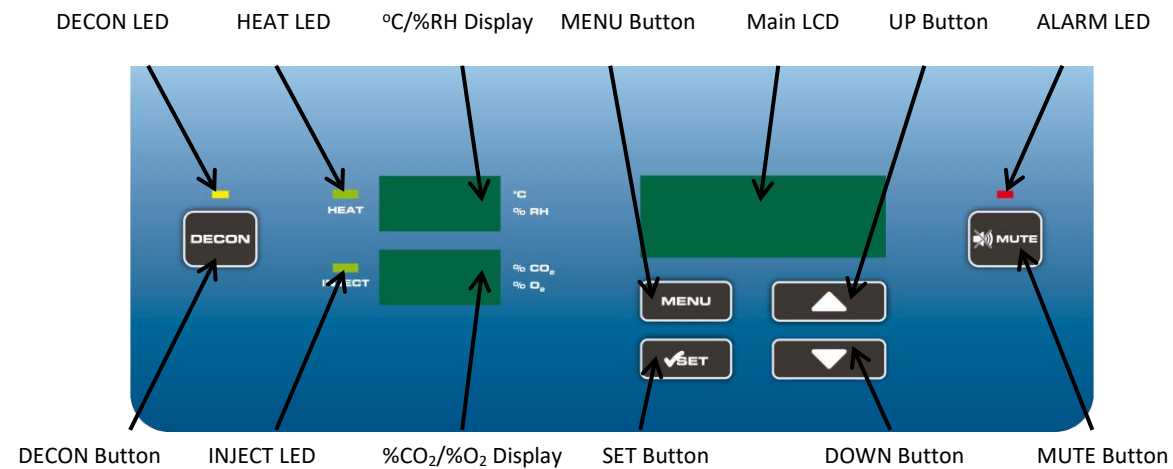

DECON Button & DECON LED

- Activates 90°C moist heat decontamination procedure
- During decontamination procedure, the yellow DECON LED will light up.

MENU Button

- When the main LCD shows normal display, pressing the MENU button will display the menu options.
- Within the menu display, pressing the MENU button will bring back the previous menu level.

SET Button

- Within the menu display, pressing the SET button will confirm a selection or value.

UP/DOWN Buttons

- Within the menu display, pressing the UP and DOWN buttons will scroll the display up and down.
- When an input is required, pressing the UP and DOWN buttons will increase and decrease a value.

MUTE Button & ALARM LED

- MUTE button will mute the audible alarm for a period of time.
- The red ALARM LED will light up whenever an alarm condition is triggered.

HEAT LED

- HEAT LED will light up whenever a heating process is activated.

INJECT LED

- INJECT LED will light up whenever a gas injection process is activated.

°C/%RH Display

- When °C is displayed, the display indicates the temperature in the chamber.

- When %RH is displayed, the display indicates the relative humidity in the chamber (optional).

%CO₂/%O₂ Display

- When %CO₂ is displayed, the display indicates CO₂ concentration level in the chamber
- When %O₂ is displayed, the display indicates O₂ concentration level in the chamber (for suppressed O₂ model only)

3.2. Menu Options

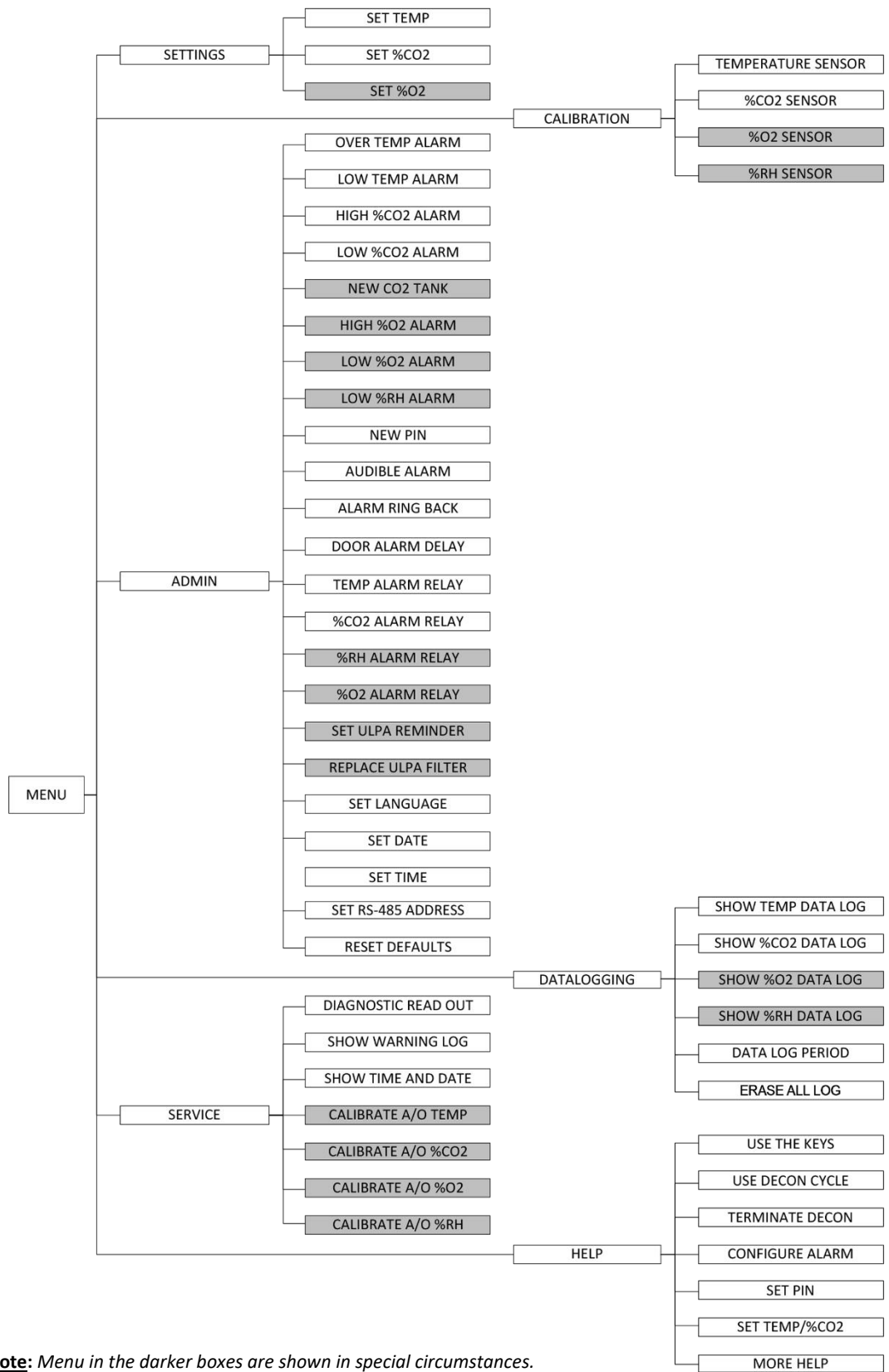

Note: Menu in the darker boxes are shown in special circumstances.

3.2.1. Settings

3.2.1.1. Set Temperature

Your incubator has an operating temperature range of ambient +5°C to 60°C. The default temperature set point is 37°C. Range control is 20.0 < T (°C) < 60.0. Temperature control will be disabled when set at 20.0°C and at 60.0°C. Set point for temperature can be adjusted in steps of 0.1 °C. Set the temperature to 59.9°C if 60°C is needed for incubation and set to 20.1°C if 20°C is needed.



Note: Ambient +5 is also applicable for lower temperature set point. Should it be set at ≤ 28°C, water pan needs to be removed/emptied to prevent condensation. An additional setup such as a dehumidifier might be needed otherwise, as there is a humidity requirement where the max. %RH in the incubator should not be higher than the room’s %RH.

3.2.1.2. Set %CO₂

Your Incubator has a range of 0% -19.5% CO₂. The default CO₂ set point is 5%. Range control is 0 < %CO₂ < 19.5. Control for %CO₂ will be disabled when set at 0.0% and at 19.5%. Set point for %CO₂ can be adjusted in steps of 0.1%. Set the %CO₂ to 19.4% if 19.5% is needed for incubation.

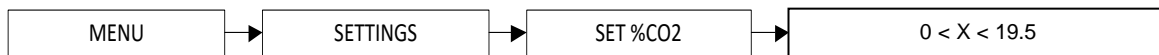

3.2.1.3. Set %O₂ (for suppressed O₂ model)

Your Incubator has a range of 1% -18% O₂. The default O₂ set point is 5%. Range control is 1.0 ≤ %O₂ < 18. Control for %O₂ will be disabled when set at 18%. Set point %O₂ can be adjusted in steps of 0.1%.

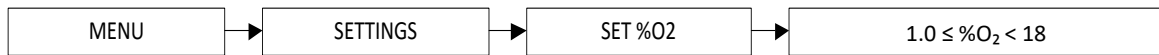

3.2.2. Calibration

3.2.2.1. Unit Calibration

After the unit has stabilized (recommended to run overnight), the temperature and CO₂ sensors can be calibrated. In the calibration mode, the temperature, CO₂, O₂ (for suppressed O₂ model), and RH (for units with optional humidity display) reading can all be calibrated to reference instruments. To determine the exact measured value of the sensors, a comparison measurement has to be performed every year. If a major deviation is found during this check, calibration of the sensor is required. This is to ensure continuous and optimal performance of the CO₂ incubator.

A calibrated measuring instrument with higher accuracy as a reference instrument is required.

Place the reference instrument or its measuring probe on the center of work zone. Route the connecting cable through the access port located at the rear of work zone, and highly to seal the access port tightly once cables are placed there. Close doors and wait until the value displayed in the reference instrument is stabilized. Record the measured value.

Enter MENU|CALIBRATION and select the responding options. When asked, enter the measured value. Press SET to confirm.

When calibrating the zirconia O₂ sensor: If the difference value between the incubator’s display reading and the reading from the reference instrument is ≥1.0%, it is recommended to do resetting of the O₂ sensor following the instructions below.

Resetting the O₂ sensor: When resetting the O₂ sensor, prepare an electronic gas analyzer and the magnetic rear access port plug then follow below procedure:

By default magnetic rear access port plug for 170/240L is installed directly to the unit from the factory.



By default magnetic rear access port plug for 50L is NOT installed directly to the unit from factory. This plug can be found in retrofit kit box.



For 50 L models:

1. Disconnect CO₂ and N₂ gas injection from the unit. No gas allowed during doing reset calibration.
2. Open the outer door and the inner glass door to allow the temperature in the chamber to be similar to the ambient temperature (e.g. ambient temperature is 25°C, then recommended incubator temperature on display should be around 24°C to 26°C).



3. Once temperature has stabilized, remove the original plug and install the **rear access port plug with magnet** to the **left** rear access port hole inside the chamber for 10 seconds then check the %O₂ actual display on the incubator control panel which should have changed to 17.7% to 18%.

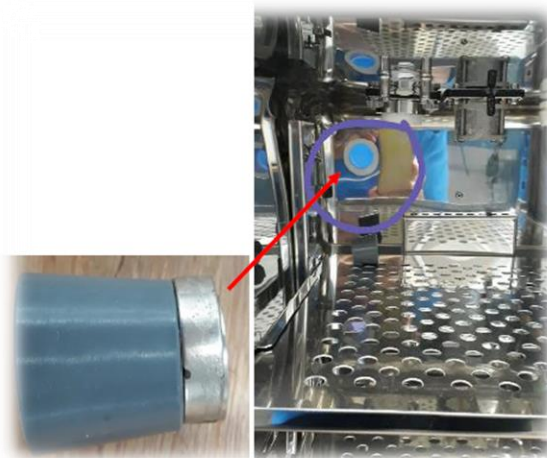

4. Remove the rear access port plug with magnet and install back the original plug without magnet to the left rear access port hole and close the chamber doors. Set the %CO₂ and %O₂ to 5.0% and allow gas to be injected.
5. Allow the unit to stabilize for 1 hour, then measure the %CO₂/%O₂ concentration by inserting around 10cm of electronic gas analyzer tubing through the sampling port on the glass door of the chamber. Turn on the pump of the gas analyzer and wait for 5 minutes when the O₂ reading has stabilized.
6. Check if there is a difference between the readings from the gas analyzer and from the incubator actual display. Set the O₂ offset (MENU > CALIBRATION > %O₂ SENSOR > CALIBRATE) when needed.

For 170/240 L models:

1. Disconnect CO₂ and N₂ gas injection from the unit. No gas allowed during doing reset calibration.
2. Open the outer door and the inner glass door to allow the temperature in the chamber to be similar to the ambient temperature (e.g. ambient temperature is 25°C, then recommended incubator temperature on display should be around 24°C to 26°C).



3. Once temperature has stabilized, install the **rear access port plug with magnet from left side** to the **right** rear access port hole inside the chamber for 10 seconds. Check the %O₂ actual display on the incubator control panel which should have changed to around 17.7% - 18%.



4. Remove the rear access port plug with magnet and install back to the left rear access port hole and close the chamber doors. Set the %CO₂ and %O₂ to 5.0% and allow gas to be injected.

5. Allow the unit to stabilize for 1 hour, then measure the %CO₂/%O₂ concentration by inserting around 10cm of electronic gas analyzer tubing through the sampling port on the glass door of the chamber. Turn on the pump of the gas analyzer and wait for 5 minutes when the O₂ reading has stabilized.
6. Check if there is a difference between the readings from the gas analyzer and from the incubator actual display. Set the O₂ offset (MENU > CALIBRATION > %O₂ SENSOR > CALIBRATE) when needed.

To reset the temperature, CO₂, and RH sensors to its default calibration, select DEFAULT CALIBRATION. Press SET button to confirm.

3.2.2.2. Analog Output Calibration (for units with optional analog output)

A set of relay contacts are provided at the rear of the incubator to allow the unit to output analog signals representing the temperature, %CO₂, %O₂ (for suppressed O₂ model), and %RH (for units with optional humidity display) depending on the options available in your incubator. This allows the chamber to be connected to an in-house data acquisition or alarm system.

The analog data output can be set to operate in either DC (0-5V) or current (4-20mA) mode. The factory default setting is voltage. The voltage of the analog output can be calibrated using a calibrated digital multimeter.

To calibrate	Rear Panel Terminal	MENU SERVICE
Temperature Analog Output	Temp (+ and -)	Calibrate A/O Temp
CO ₂ Analog Output	CO ₂ (+ and -)	Calibrate A/O CO ₂
% Relative Humidity Analog Output	RH (+ and -)	Calibrate A/O RH
O ₂ Analog Output	O ₂ (+ and -)	Calibrate A/O O ₂

Place the multimeter’s measuring probe on the responding + and - terminals of the analog output located on the rear panel and record the measured value.

Enter MENU|SERVICE and select the responding options. When asked, enter the measured value. Press SET to confirm.

3.2.3. Admin

3.2.3.1. Over Temperature Alarm

The unit will display/sound the alarm when the temperature goes above the over temperature alarm value. The default over temperature alarm is temperature set point + 1°C.



3.2.3.2. Low Temperature Alarm

The unit will display/sound the alarm when the temperature goes below the low-temperature alarm value. The minimum low temperature alarm value that can be set in all CCL models except CCL with Peltier Cooling System is 19.0°C. The minimum low temperature alarm value in CCL with Peltier Cooling System is 0.0°C. The default low-temperature alarm is temperature set point - 1°C.

Note: *The low-temperature alarm will only be activated once the unit reaches the temperature set point.*

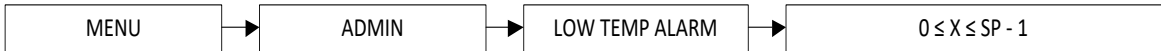

3.2.3.3. High %CO₂ Alarm

The unit will display/sound the alarm when the CO₂ level goes above the high %CO₂ alarm value. The default high %CO₂ alarm is %CO₂ set point + 1%.

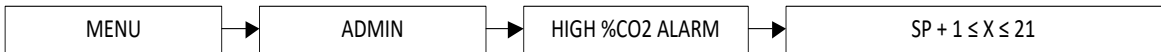

3.2.3.4. Low %CO₂ Alarm

The unit will display/sound the alarm when the CO₂ level goes below the low %CO₂ alarm value. The default low %CO₂ alarm is %CO₂ set point - 1%.

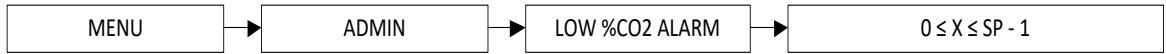

3.2.3.5. High %O₂ Alarm (for suppressed O₂ model)

The unit will display/sound the alarm when the O₂ level goes above the high %O₂ alarm value. The default high %O₂ alarm is %O₂ set point +1%.

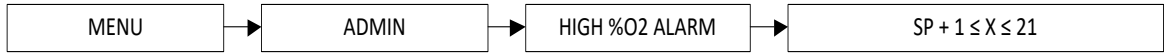

3.2.3.6. Low %O₂ Alarm (for suppressed O₂ model)

The unit will display/sound the alarm when the O₂ level goes below the low %O₂ alarm value. The default low %O₂ alarm is %O₂ set point -1%.

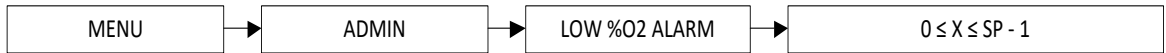

3.2.3.7. Low %RH Alarm (for unit with optional RH display)

The unit will display/sound the alarm when the RH level goes below the low %RH alarm value. The default low %RH alarm is 75%.

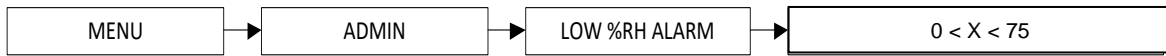

3.2.3.8. New PIN

PIN restricts access to Menu functions. User must enter 4-digit PIN before accessing MENU. Default PIN is 0000 (Disabled).

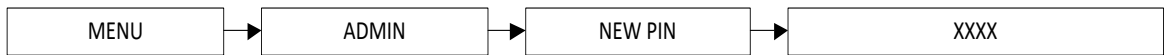

3.2.3.9. Audible Alarm

Audible alarms can be enabled or disabled, however the visual alarm will still be active even after the audible alarm is disabled.



3.2.3.10. Alarm Ring Back Time

When the system encounters an error, it will sound the audible alarm. The user can temporarily press MUTE button to disable the sound. If the error is not corrected within the time set within this option, the audible alarm will be re-enabled.



3.2.3.11. Door Alarm Delay Time

To set the delay time for door alarm. Delay time can be set between 1 to 15 minutes. Default is 15 minutes.



3.2.3.12. Relay Activation

SPDT switch can be wired as normally open (NO) or normally close (NC) and common (COM). Rating of the switch is maximum 30VDC, 2A. The purpose of alarm relay is to facilitate monitoring. When there is a fault in the system pertaining to the relevant parameter (temperature, %CO₂, %O₂ (for suppressed O₂ model) or %RH (for units with optional %RH display), the relay will make or break to signal to a remote device that the incubator is in a faulty condition.

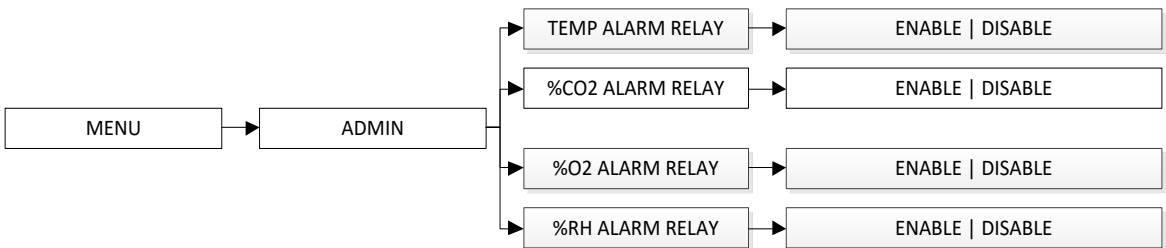

3.2.3.13. Set ULPA Reminder (For 170L & 240L models)

The ULPA Reminder will alert the user to replace ULPA filter at a set period. Default is set to 12 months.



3.2.3.14. Replace ULPA Filter (For 170L & 240L models)

The replace ULPA filter settings must be set when replacing ULPA filter in order for the set ULPA Reminder to reset based on the set period.

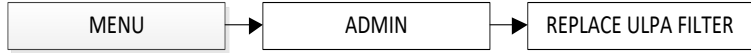

3.2.3.15. Set UV Schedule (For units with UV lamp only)

The UV lamp will turn on based on the set UV schedule. Default is 02:00 AM.



3.2.3.16. Set UV Timer (For units with UV lamp only)

The UV Timer determines how long the UV lamp will light up based on the preset period of time. Default is 30 minutes.

Note: *If the outer door is opened while the UV lamp is lit, the lamp will turn off. When the door is closed, the lamp will light for the preset period of time.*



3.2.3.17. Set UV Reminder (For units with UV lamp only)

The UV Reminder will alert the user to replace the UV lamp. The recommended replacement time for the UV lamp is when the accumulated active time reaches 1000 hours (default).



3.2.3.18. Replace UV Lamp (For units with UV lamp only)

The Replace UV Lamp setting must be set when replacing UV lamp in order for the Set UV Reminder to reset based on the set period.

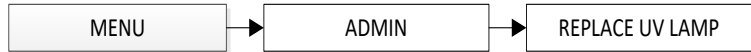

3.2.3.19. Set Language

List of language available includes English, Spanish, German, French and Italian.

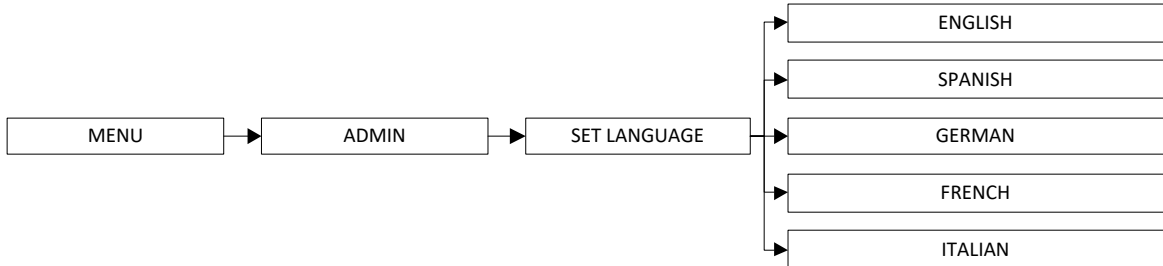

3.2.3.20. Set Date

User can set the date and it will be maintained even after the unit is turned off. The format is YYYY MM DD.

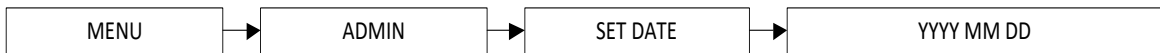

3.2.3.21. Set Time

User can set the time and it will be maintained even after the unit is turned off. The format is HHMMSS.

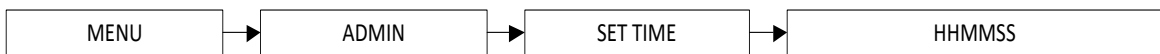

3.2.3.22. Set RS-485 Address (for unit with optional Voyager® monitoring software)

User can set the RS-485 address for PC connection.



3.2.3.23. Reset Default

User can reset the unit to the factory default settings by choosing this option. The features being reset are all set points and alarms.

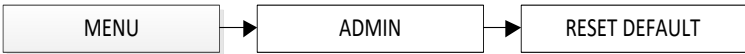

3.2.4. Data Logging

3.2.4.1. Show Data Log

User can set to show temperature, %CO₂, %O₂ (for suppressed O₂ model) and %RH (for units with optional RH display) data log. The data format is MMDDYY HHMM INFO. Use the UP/DOWN buttons to read through the log. Press MENU to go back to previous level.

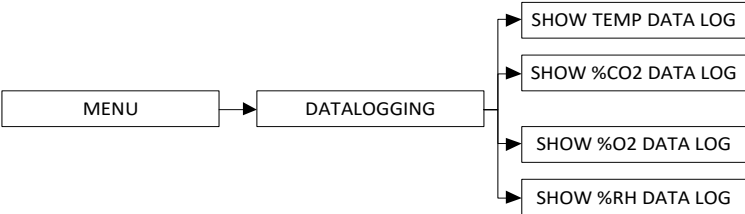

3.2.4.2. Data Log Period

The Data Log Period allows the user to specify the period in between the system log the data. The period can be set from 0 minute up to 24 hours.



3.2.4.3. Erase All Log

The Erase All Log allows the user to delete the data logs. Press SET to erase data logs and press MENU to cancel deleting the data logs.

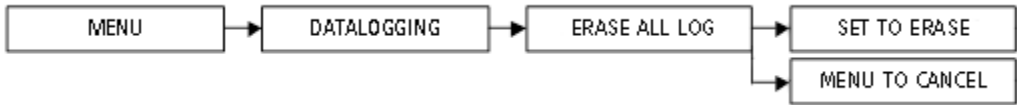

3.2.5. Service

3.2.5.1. Diagnostic Readout

This menu will show all parameters and set points that are currently being set or operating in the incubator. See section 3.4 Diagnostic Readout. Use the UP/DOWN buttons to read through the readout. Press MENU to go back to the previous level.



3.2.5.2. Show Warning Message

This will display the description of the error with date and time. The user can scroll down or up if the error message is too long. It will only display up to a maximum of 32 error messages after which the new errors will override the old error messages. Use the UP/DOWN buttons to read through the log. Press MENU to go back to the previous level.



3.2.5.3. Show Date & Time

Shows the actual time and date – based on the value input in set time and set date or during the first run.



3.2.5.4. Calibrate Analog Output

See section 3.3.2 Analog Output Calibration for the instruction.

3.2.6. Help

This menu section will show brief explanation on the basic control of the unit.

3.3. Operation of CO₂ Incubator with Peltier Cooling System (applicable for CCL-P series)

3.3.1. Cooling Mode

To activate the cooling mode, set the temperature to any point lower than the currently displayed value by accessing settings. Press SET button once, press MENU to go back to normal display and wait for 4-5 seconds until the operation mode display appears as shown below:



Cooling mode control range: 8°C below ambient



Note: The incubator is working according to the room temperature. Stable room/ambient temperature is therefore required. When the temperature set point is equal to or below the ambient temperature, put empty water pan in the chamber or if it has water, drain first and put back the dried pan inside the chamber.

3.3.2. Heating Mode

To activate the heating mode, set the temperature to any point higher than the currently displayed value by accessing settings. Press SET button once, press MENU to go back to the normal display and wait for 4-5 seconds until the operation mode display appears as shown below:



3.4. Diagnostic Readout

Messages	Description
MAIN_BOARD	Main board firmware version.
DISP_BOARD	Display board firmware version.
TEMP READ	Snap shot of actual temperature reading.
ADC TEMP	Snap shot of actual Analog to Digital Conversion value of temperature read.
TEMP OFFSET	Offset value applied for temperature reading on 7 segment display.
TEMP SP	Temperature set point.
OV TEMP SP	Over temperature alarm set point.
LO TEMP	Low temperature alarm set point.
%CO ₂ READ	Snap shot of actual CO ₂ level read.
CO ₂ OFFSET	Offset value applied for CO ₂ level reading on 7 segment display.
%CO ₂ SP	CO ₂ level set point.
HI %CO ₂ SP	High CO ₂ level alarm set point.
LO %CO ₂ SP	Low CO ₂ level alarm set point.
%O ₂ READ	Snap shot of actual O ₂ level read.*
ADC %O ₂	Snap shot of actual Analog to Digital Conversion value of O ₂ level read.*
%O ₂ SLOPE	Offset value applied for O ₂ level reading on 7 segment display.*
%O ₂ SP	O ₂ level set point.*
HI %O ₂ SP	High O ₂ level alarm set point.*
LO %O ₂ SP	Low O ₂ level alarm set point.*
%RH READ	Snap shot of actual RH level read.**
ADC %RH	Snap shot of actual Analog to Digital Conversion value of RH level read.**
%RH OFFSET	Offset value applied for RH level reading on 7 segment display.**
%RH SETTING	Humidity level setting. High humidity will show LVTD. Default humidity will show DFLT.
LO %RH SP	Low RH level alarm set point.**
DOOR SWITCH	Door switch status of OPEN or CLOSE.
DOOR DELAY	Door open alarm delay set point.
THERMOSTAT	Thermostat status of OPEN or CLOSE.
MAIN HTRDCY	Percentage of average duty cycle of the main heater work over an hour.
BASE HTRDCY	Percentage of average duty cycle of the base heater work over an hour.
DOOR HTRDCY	Percentage of average duty cycle of the door heater work over an hour.
%CO ₂ INJDCY	Percentage of average duty cycle of the CO ₂ solenoid valve work over an hour.
%O ₂ INJDCY	Percentage of average duty cycle of the O ₂ solenoid valve work over an hour.*
CO ₂ TANK 1	If CO ₂ BACKUP is not installed then it will show the percentage of remaining capacity of CO ₂ tank. If CO ₂ BACKUP is installed then it will show OK or NOK of the CO ₂ tank capacity.***
CO ₂ TANK 2	Will show OK or NOK of the CO ₂ tank 2 capacity.***
N ₂ TANK 1	Will show OK or NOK of the N ₂ tank 1 capacity.****
N ₂ TANK 2	Will show OK or NOK of the N ₂ tank 2 capacity.****
AUDIBL ALRM	Audible alarm status of "EN"able or "DIS"able.
RING BACK T	Current ring back time value
DA DELAY	Door Alarm Delay period: 5 mins.
TEMP RELAY	Temperature alarm condition is "EN"able or "DIS"able for activating the remote alarm relay.
CO ₂ RELAY	CO ₂ level alarm condition is "EN"able or "DIS"able for activating the remote alarm relay.
O ₂ RELAY	O ₂ level alarm condition is "EN"able or "DIS"able for activating the remote alarm relay.*
RH RELAY	RH level alarm condition is "EN"able or "DIS"able for activating the remote alarm relay.**
ULPA REMAIN	ULPA remaining life time in months.
ADDRESS	RS-485 address for this CO ₂ Incubator.
LOG PERIOD	Log period applied in minutes or hours.
FLASH MEM	Total of FLASH memory used to keep the record of data log or warning log.

* Only available for Suppressed O₂ model

** Only available for units with RH display options installed

*** Only available for units with CO₂ backup options installed

**** Only available for units with N₂ backup options installed

3.5. Alarm

The CelCulture® CO₂ Incubator alarm system is shown in the table below. When an alarm is active, the error message appears in the display of the controller. Pressing MUTE button will disable the audible alarm for the ring back period. However, the visual alarm continues until the incubator returns to a normal condition.

Alarm name	Condition indicated	Alarm Delay	Additional notes
Temp sensor error	ADC reading is in overflow or reads less than 10 counts	No delay	7 seg display will show "----"; heating will be disabled
CO ₂ sensor error	ADC reading is in overflow or reads less than 20 counts	No delay	7 seg display will show "----"; CO ₂ injection will be disabled
O ₂ sensor error*	ADC reading is in overflow or reads less than 20 counts	No delay	7 seg display will show "----"; N ₂ injection will be disabled
RH sensor error**	ADC reading is in overflow or reads less than 20 counts	No delay	7 seg display will show "----"
Over temperature	Temp reading plus calibration offset is greater than overtemp setting	No delay	Heating is disabled, display shows temp reading
High CO ₂ level	CO ₂ reading plus calibration offset is greater than high CO ₂ setting	15 minutes	CO ₂ injection is disabled, display shows CO ₂ reading
High O ₂ level*	O ₂ reading plus calibration offset is greater than high O ₂ setting	15 minutes	N ₂ injection will not stop. Display shows O ₂ reading
Door open	Door has been open for over 'DOOR ALARM DELAY' time	1 - 15 minutes	All gas injections and chamber fan stop without delay. Heating disabled.
Low %RH**	%RH reading plus calibration offset is lower than low %RH setting	2 hours	Display continues to report %RH as read
Low temperature	Temp reading plus calibration offset is lower than low temp setting	15 minutes	Display continues to report temp as read
Low CO ₂ level	CO ₂ reading plus calibration offset is lower than low CO ₂ setting	15 minutes	Display continues to show CO ₂ reading
Low O ₂ level*	O ₂ reading plus calibration offset is lower than low O ₂ setting	15 minutes	Display continues to show O ₂ reading, N ₂ injection should be disabled
All CO ₂ tanks low	Pressure switch on both CO ₂ tanks indicate low pressure	No delay	Display continues to show CO ₂ reading
All N ₂ tanks low****	Pressure switch on both N ₂ tanks indicate low pressure	No delay	Display continues to show O ₂ reading
CO ₂ tank 1 low***	Pressure switch on CO ₂ tank 1 indicate low pressure and backup is installed	15 minutes	Solenoid control automatically switches to CO ₂ tank 2. Display shows CO ₂ reading
CO ₂ tank 2 low***	Pressure switch on CO ₂ tank 2 indicate low pressure and backup is installed	15 minutes	Solenoid control automatically switches to CO ₂ tank 1. Display shows CO ₂ reading
N ₂ tank 1 low****	Pressure switch on N ₂ tank 1 indicate low pressure and backup is installed	15 minutes	Solenoid control automatically switches to N ₂ tank 2. Display shows O ₂ reading
N ₂ tank 2 low****	Pressure switch on N ₂ tank 2 indicate low pressure and backup is installed	15 minutes	Solenoid control automatically switches to N ₂ tank 1. Display shows O ₂ reading
ULPA reminder	Timer reminder for ULPA replacement has been reached	No delay	
CLOSE REAR ACCESS*****	Reminder to close or plug back rear access port plug after decontamination complete	No delay	During normal operations, rear access port must be closed. Opening the rear access port plug can reduce the humidity and will cause the gas to leak
OPEN REAR ACCESS*****	Reminder to open or unplug rear access port plug before decontamination started	No delay	During Decon cycle, rear access port must be open as moist heat exhaust port
BACKUP RUNNING	Overshooting of temperature display to + 0.4°C of the setpoint for more than 30 times indicates failure in the mainboard setting system.	No delay	The alarm can be cleared after a door opening.
CHECK CO ₂ SYSTEM	%CO ₂ display stuck at <0.5% over the setpoint indicates failure in CO ₂ sensor probe, CO ₂ solenoid valve, and/or the CO ₂ tank supply.	No delay	The system will automatically stop the solenoid valve from injecting CO ₂ to prevent depletion of CO ₂ tank supply. Users will be able to clear the message and return the CO ₂ injection system by opening and closing the door.

* Only available for Suppressed O₂ model

** Only available for units with RH display options installed

*** Only available for units with CO₂ backup options installed

**** Only available for units with N₂ backup options installed

***** Only available for 170L and 240L units

Chapter 4 - General Maintenance

4.1. Scheduled Maintenance

Proper and timely maintenance is crucial for trouble-free functioning of any device, and your CO₂ incubator is no exception to this rule. We strongly recommend that you follow the maintenance schedule suggested hereunder in order to obtain optimal performance from your incubator.



Note: If the device is placed in a H₂O₂ decontaminated room, all parts of the device exposed to the environment need to be covered during the room decontamination process

No	Description of Task to Perform	Maintenance to be carried out			
		Daily	Weekly	Yearly	As Needed
1	Check CO ₂ /N ₂ gas tank level	√			
2	Check water level in the water pan		√		
3	Cleaning the interior and exterior of incubator		√		
4	Calibration of O ₂ sensor			√	√
5	General Inspection			√	
6	Calibration of temperature sensor			√	
7	Calibration of CO ₂ sensor			√	
8	Calibration of humidity sensor			√	
9	Change ULPA filter (170L/240L)			√	
10	Change inlet filters			√	
11	Change outer door magnetic gasket*				√
12	Decontamination				√
13	Change UV lamp (for units with UV lamp)				√

*Replace if it has been damaged or when necessary.

Cleaning instruction for Cu model: There is no need for additional agents or water additives compared to cleaning the Stainless-Steel chamber as outlined in this manual. It is normal that Copper (Cu) chamber interior will have discoloration after a period of time. This is a sign of patina, which is a thin layer that forms on the surface due to exposure to air, moisture, and heat. It often appears as greenish or brownish film and is a natural result of oxidation. While it may alter the appearance, it can protect against further corrosion. However, heavy tarnishes or buildup may need to be addressed to ensure the chamber's cleanliness and functionality. If the tarnish is affecting the performance or if there are contamination concerns, it may be necessary to remove it using vinegar, baking soda or lemon soap. Smooth/fine sandpaper can be used to remove the stain.

4.1.1. Check CO₂/N₂ Gas Tank Level

Check the pressure gauge on the two-stage gas regulator daily to ensure the pressure is not below 15 psig. Replace with a new tank if necessary.

4.1.2. Check Water Level in the Water pan

Check weekly to ensure there is sufficient water in the pan. It is recommended to check the water level and refill the water pan with sterile distilled water once a week.

4.1.3. Cleaning and Decontamination

See *Chapter 5—Cleaning & Decontamination*

4.1.4. General Inspection

Check the following regularly – at least annually:

- Tightness of the glass door seal
- Functional check of the operating panel and device control
- Electrical safety check in accordance with the relevant regulations
- Check tightness of hinge screws on door's moving parts
- Check the latch of glass door if working properly and able to close tight

4.1.5. Calibration of Temperature, CO₂, O₂ and Humidity

See *section 3.2.2 - Calibration*

4.1.6. Change ULPA Filter (CCL-170L & CCL-240L only)

See section 2.2.3 - *ULPA Filter Installation*

4.1.7. Change Inlet Filter

Inlet filters are installed to remove any contaminant in the CO₂ or N₂ gas supply. It prevents accumulation of dirt in the gas inlet solenoid valves and tubes leading into the work area of the incubator. Change the inlet filters at least once a year or when the filter is dirty by visual inspection. Use the hose clamp to secure the tubing to the filter to ensure a gas-tight connection.

4.1.8. Change Outer Door Magnetic Gasket

The magnetic door gasket installed in the outer door of the incubator helps to keep a tight seal around the chamber opening. It is recommended to check the magnetic door gasket for signs of brittleness, corrosion, wearing, or any form of damage once a year. Replace the outer door magnetic gasket if it has been damaged or when necessary.

4.1.9. Change UV Lamp (for units with UV lamp)

The UV lamp ensures that the circulating air and the water reservoir remains free of microorganisms and contaminants. It is isolated from the inner chamber by the lower and back plenum cover to ensure that the cultures are not affected by UV decontamination. To change the UV lamp, remove the back and lower plenum covers by unscrewing them from the chamber. Replace the UV lamp and reinstall the plenum covers. Make sure that the plenum covers are reinstalled properly and that the UV lamp is fully covered to avoid UV leak into the culture chamber. It is advisable to change the UV lamp every 1000 hours of running time (approximately around 4 years).

4.2. Maintenance/Service Log

It is good practice (and in some cases regulatory requirement) to maintain a log of all maintenance work carried out on your incubator.

NO.	DATE/TIME	DESCRIPTION OF MAINTENANCE/SERVICE TAKEN	DONE BY	REMARKS
1				
2				
3				
4				
5				
6				
7				
8				
9				
10				
11				
12				
13				
14				
15				
16				
17				
18				
19				
20				

Chapter 5 - Cleaning & Decontamination

5.1. Cleaning Procedure

1. During the cleaning process, the operator should use Personal Protective Equipment (PPE) according to the provisions of the laboratory.
2. Prepare the materials needed for the cleaning process such as mild soap solution, distilled water in a wash bottle, sponge, clean cloth or tissue, disinfectant, and wash tray or bucket (if a sink is not available).



Note: Metal surfaces can be cleaned using stainless steel cleaning agents. The inner glass door surfaces can be cleaned using glass cleaners. Never use chlorine-based disinfectants!

3. Transfer all samples to another CO₂ incubator or store them in a safe place.
4. Turn off and unplug the device. If needed, mark that the unit is deactivated or being serviced.
5. Strip the unit for cleaning:
 - a. Remove the top plenum.



Note: For models with O₂ sensor, the sensor generates heat in order to prevent condensation around it. Be careful not to touch the sensor probe.

Remove the front thumb screws.



Remove the thumb screws located at the back of the chamber.



Gently unhook the back of the plenum and pull it out from the chamber.

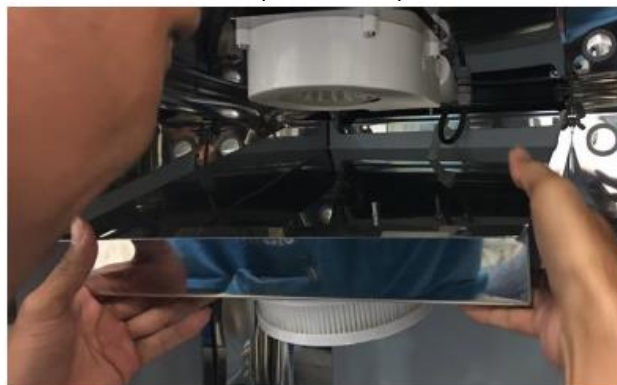

Unplug the rear access port plug and remove the inlet filter.

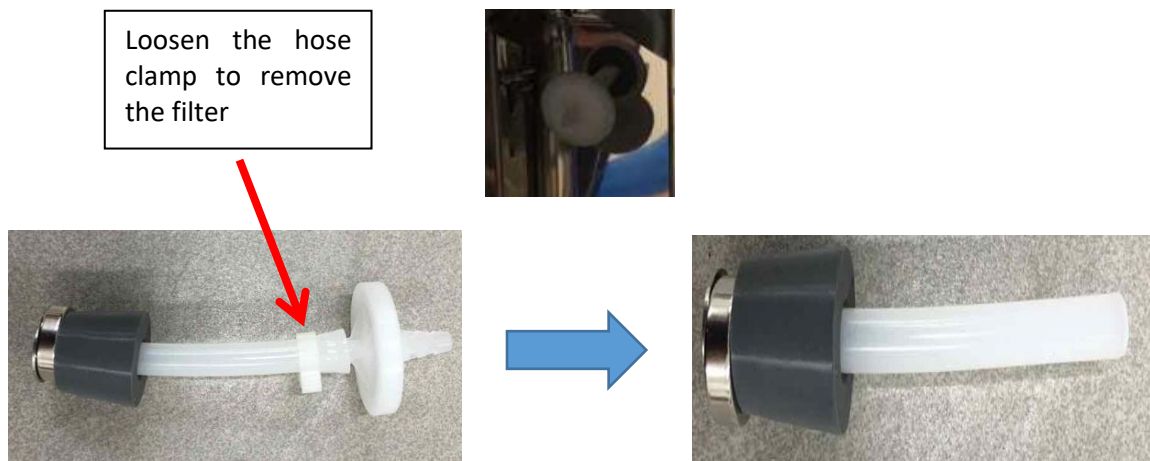

Plug the rubber cover at the left and right access port.

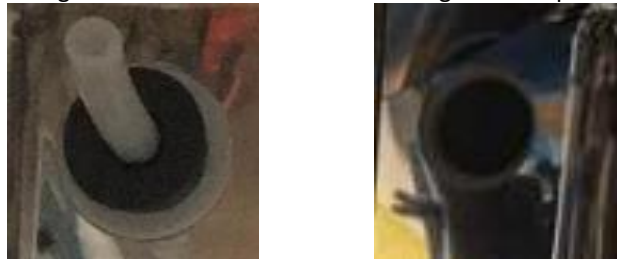

b. Remove the shelf system. See *section 2.2.4 Shelves System Installation*.

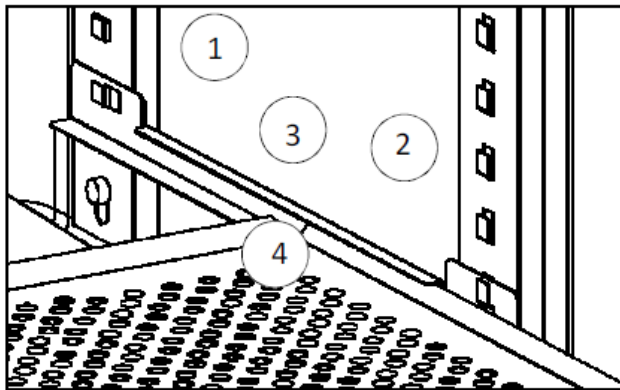

Items:

1. Back Pilaster
2. Front Pilaster
3. Railing
4. Tray or Shelf

Procedure:

1. Remove the tray or shelf.
2. Remove the railing by removing the front end upward from the front pilaster and moving the back end backward from the back pilaster.
3. The pilaster can be removed by unscrewing the thumb screws holding the pilasters.

c. Remove the sparger and tubing (for suppressed O₂ model) and the water pan.

6. Start the cleaning process:



Note: When cleaning and disinfecting, always observe the safety instructions and hygiene regulations.

- a. Thoroughly remove dirt and residues from the surfaces of the work space using the mild soap solution and a sponge, or spray an appropriate disinfectant onto work space surfaces and all dismantled parts. Allow disinfectant to react as specified by manufacturer.

Note: Do not spray disinfectant directly onto sensors, on the control panel, and on surfaces near the electrical panel to prevent damage to electrical parts. Use a cloth soaked with disinfectant to wipe the control panel and the exterior body.

- b. Rinse the soap solution or disinfectant twice using the distilled water in a wash bottle. If the part is hard to rinse with a wash bottle, use a wet sponge to remove the soap.
 - c. Dry all rinsed part with a clean lint-free cloth or paper towel.
 - d. Wipe the interior components and exterior surfaces with 70% ethanol then allow to dry.
7. Re-assemble the unit by reversing step 5. Ensure that the equipment has completely dried before commencing normal operation.

Note: Surface of a CO₂ incubator with copper chamber (CCL-Cu) is prone to dirt & fingerprint marks (once touched with hands) and has a tendency to give a greenish appearance when oxidation occurs (upon contact with carbon dioxide). Clean regularly with lemon soap, vinegar or baking soda. About 1 tablespoon of salt per 1 cup of vinegar can be also used to remove tarnishes. If the surface or the water pan turned green, use sand paper. Contact your Local Distributor for the available passivation solution to use.

5.2. Decontamination

Decontamination in CelCulture® CO₂ incubator uses 90°C moist heat to kill organisms that commonly contaminate workspace including all installed components. The entire program run of the decontamination routine takes approximately 15 hours (overnight process). The chamber is cool and dry at the end of the cycle (applicable to CCL-170L/240L units only). No further wipe down is necessary.

Note: CCL-50L unit does not have a decon pump to dry the chamber after the decontamination cycle. Further wipe down of the chamber is required for CCL-50L models since condensation will normally occur after the cycle.



Note: The incubator must not be used to decontaminate objects other than the incubator and its components.

5.2.1. Decontamination Procedure

- Press the DECON button. And follow the instruction in the main display.
- No need to remove the following items:
 1. Blower
 2. RH Sensor
 3. O₂ Sensor (if installed)
 4. IR CO₂ Sensor
 5. Temperature Sensor
- Remove the left rear access port plug (for CCL-170L/240L units only); no need to remove the rear access port plug in CCL-050L unit).
- For unit that comes with water pan cover, remove the cover from water pan and place it on either one of the shelves during decontamination.
- Keep the ULPA filter inside the incubator during decontamination (for CCL-170L/CCL-240L units only).
- CCL-50L unit has no top duct, no ULPA filter installed, and has a small blower fan for forced convection. No need to remove blower during decontamination.
- Replace water from the water pan with **distilled water** according to the following volumes:



Size	Water volume for decon (ml)
CCL-050L	200
CCL-170L	400
CCL-240L	400

Once the decontamination is done:

- Reinstall rear access plug (CCL-170/240L).
- Fill in the water pan (400 ml water for CCL-050L and 800 ml for CCL-170/240L) with **distilled water**.

-
- Reinstall the water pan cover correctly according to the models. Refer to **Section 1. Products Covered** for the water pan cover code.

Chapter 6 - Troubleshooting

Under no circumstances should the unit be disassembled, repaired, or converted by unqualified people. Failure to follow these instructions may cause personal injury and/or loss of property due to malfunctions, electric shocks or fire.

Should the unit malfunction, turn off the incubator and disconnect the power supply. Continuing to operate the unit when it shows signs of malfunctioning may cause electric shocks or fire.

The following troubleshooting guidelines address some of the basic problems that can be solved by the user or operator. However, if the problem persists, please contact your local distributor.

Problem 1: Unit will not turn on

Possible Cause	Corrective Actions
Power failure	<ul style="list-style-type: none"> Is the cord set connected to the power inlet at the rear of unit as defined in the installation section of the manual? Is there power at the electrical outlet which the unit is plugged into? Use voltmeter or test pen to check power on the electrical socket. Is the unit's power switch turned on? Check whether power cord has been connected properly to the wall/building socket and also into the incubator. Check whether the power cord is giving power, measure the AC voltage between the live and the neutral terminal of the cord by using a voltmeter. If voltage is not within +/-2% of the socket voltage, replace the power cord. Check the fuse of the power cord.

Problem 2: CO₂ level is below or above CO₂ set-point

Possible Cause	Corrective Actions
Unit is not connected to the pressure regulated CO ₂ source.	<ul style="list-style-type: none"> Check gas hose connection at the rear of unit to the CO₂ source as defined in the installation section of the manual.
CO ₂ inlet pressure not regulated correctly.	<ul style="list-style-type: none"> The CO₂ inlet gas pressure should be regulated to approximately 15 psig.
CO ₂ gas tank is empty.	<ul style="list-style-type: none"> Replace CO₂ gas tank.
In-line filter is dirty / saturated.	<ul style="list-style-type: none"> Replace in-line filter.
Gas hose is leaking.	<ul style="list-style-type: none"> If hose is leaking, check the pressure regulator to ensure CO₂ inlet pressure is not more than 15 psig. Check for leakage at hose connection.
Gas hose is dirty or obstructed.	<ul style="list-style-type: none"> Check physically for dirt accumulation or obstruction, clean or replace it.
CO ₂ set-point was recently lowered or raised. Unit is still not stabilized after the set-point was changed.	<ul style="list-style-type: none"> Check CO₂ set-point. Allow 2 hours for the unit to stabilize after adjustment of new set-point. If the CO₂ set point is lowered, the outer and inner doors must be opened.
Inner door opened for an extended period of time.	<ul style="list-style-type: none"> Close the door and let the unit stabilize.
Access port stopper at the rear of the unit was removed or not install.	<ul style="list-style-type: none"> Ensure access port stopper and filter are installed.
Air leakage through inner door gasket.	<ul style="list-style-type: none"> Check installation of the gasket to ensure that it is properly secured to the unit and that there is no gap. Check the joining ends of the gasket to make sure there is no gap. Use silicon sealant to seal the joins if there is a gap. Check gasket profile is not deformed or torn. Otherwise, replace new door gasket.

Problem 3: Temperature is above or below temperature set-point

Possible Cause	Corrective Actions
Temperature set-point was recently lowered or raised. Unit is still not stabilized after set-point was changed.	<ul style="list-style-type: none"> Check temperature set-point. Allow 2 hours for the unit to stabilize after adjustment of new set-point. If the temperature was lowered, open the outer and inner doors. Lowering the temperature without opening the doors could lead to condensation. Check if the glass door latch is properly closed.
Inner door opened for an extended period of time.	<ul style="list-style-type: none"> Close the door and let the unit to stabilize.
Air leakage through Inner door gasket.	<ul style="list-style-type: none"> Check installation of the gasket to ensure that it is properly secured to the unit and that there is no gap.

	<ul style="list-style-type: none"> • Check the joining ends of the gasket to make there is no gap. Use silicon sealant to seal the joins if there is a gap. • Check gasket profile is not deformed or torn. Otherwise, replace new door gasket.
Defective mainboard	<ul style="list-style-type: none"> • Check if the triac heater is not defective. Measure the voltage (ON/OFF testing under TEST MODE). Must be <5 V when OFF. Otherwise, replace the mainboard.
Small fan position too far to O ₂ sensor	<ul style="list-style-type: none"> • Move closer the small fan to O₂ sensor housing

Problem 4: Humidity level is below standard humidity level (For units with RH display options installed)

Possible Cause	Corrective Actions
There is no water or not enough water in the water pan.	<ul style="list-style-type: none"> • Ensure there is enough water in the water pan. For normal operating temperature, water pan should be half filled.

Problem 5: Unusually high gas consumption

Possible Cause	Corrective Actions
Air leakage through inner door gasket.	<ul style="list-style-type: none"> • Check installation of the gasket to ensure that it is properly secured to the unit and that there is no gap. • Check the joining ends of the gasket to make there is no gap. Use silicon sealant to seal the joins if there is gap. • Check gasket. • Check if the glass door latch is properly closed. • Ensure access port stopper and filter are installed.
CO ₂ sensor not calibrated	<ul style="list-style-type: none"> • Calibrate CO₂ sensor.
Defective CO ₂ sensor	<ul style="list-style-type: none"> • Contact local distributor for sensor replacement.
In-line filter is dirty / saturated.	<ul style="list-style-type: none"> • Replace in-line filter.
Gas hose is leaking.	<ul style="list-style-type: none"> • If the hose is leaking, check the pressure regulator to ensure CO₂ inlet pressure is not more than 15 psig. • Check for leakage at hose connection. • Contact local distributor for new hose.
Inner door not properly closed.	<ul style="list-style-type: none"> • Close the door and let the unit stabilize.
Air leakage through inner door gasket.	<ul style="list-style-type: none"> • Check installation of the gasket ensure it is properly secure to the unit and that there is no gap. • Check the joining ends of the gasket to make sure there is no gap. Use silicon sealant to seal the joins if there is a gap. • Check gasket profile is not deformed or torn. Otherwise, replace new door gasket.

Problem 6: Circulation fan not running

Possible Cause	Corrective Actions
Main door switch is faulty.	<ul style="list-style-type: none"> • Ensure outer door is closed and pressing the door switch button. • If the fan is still not working, contact local distributor.
Faulty fan motor.	<ul style="list-style-type: none"> • Ensure outer door is closed and pressing the door switch button. • If the fan is still not working, contact local distributor.

Problem 7: Condensation occurs in the chamber.

Possible Cause	Corrective Actions
Outer door opened for an extended period of time or frequency of opening door is very high.	<ul style="list-style-type: none"> • Close the door and allow the unit to stabilize. Try to reduce the frequency of door opening.
Ambient conditions	<ul style="list-style-type: none"> • Ensure sufficient wall clearance around the chamber. • Ensure that the unit is not directly heated by sunlight. • Check the ambient temperature level. Ideal ambient temperature is at least 20°C - 24°C (68°F - 75°F). If ambient temperature is not in the range of 20°C - 24°C, the temperature of the unit must be calibrated. • Check the ambient humidity level. Ideal ambient humidity level is 60%. Ensure that ambient humidity level is non-condensing. • Door and perimeter heater must be adjusted according to ambient conditions. Contact local distributor for heater adjustment.
Power interruption occurred overnight	<ul style="list-style-type: none"> • Take out the water pan and wipe the incubator surface • Set the temperature to 55°C and let the unit heat up for one hour • Turn off the unit and open the incubator doors to allow the unit to cool down • Turn on the unit and set the temperature back to the intended set point. Fill the water pan with sterile distilled water according to the water level required.

Problem 8: Water accumulated at the base of the chamber.

Possible Cause	Corrective Actions
Condensed water from the cold spot did not drip back to the water pan.	<ul style="list-style-type: none"> Ensure the water pan is pushed all the way to the back so that condensed water from the cold spot drips into water pan.

Problem 9: Small fan is not working (for CCL-050_--_)

Possible Cause	Corrective Actions
Defective fan	<ul style="list-style-type: none"> Ensure that the voltage supply from J-10 is 12.0 VDC. Otherwise, replace the mainboard.

Problem 10: CO₂ Sensor error

Possible Cause	Corrective Actions
Power interruption occurred overnight	<ul style="list-style-type: none"> Take out the water pan and wipe the incubator surface Set the temperature to 55°C and let the unit heat up for one hour Turn off the unit and open the incubator doors to allow the unit to cool down Turn on the unit and set the temperature back to the intended set point. Fill the water pan with sterile distilled water according to the water level required.
Defective supply from J-10 I-series mainboard	<ul style="list-style-type: none"> Relay optional supply from SMPS. Contact local distributor.
Broken cable or cable connection	<ul style="list-style-type: none"> Contact local distributor
Defective CO ₂ probe	<ul style="list-style-type: none"> Contact local distributor.
Defective CO ₂ board	<ul style="list-style-type: none"> Contact local distributor.

Problem 11: O₂ Sensor Error

Possible Cause	Corrective Actions
Power interruption occurred overnight	<ul style="list-style-type: none"> Take out the water pan and wipe the incubator surface Set the temperature to 55°C and let the unit heat up for one hour Turn off the unit and open the incubator doors to allow the unit to cool down Turn on the unit and set the temperature back to the intended set point. Fill the water pan with sterile distilled water according to the water level required.
Sensor needs calibration.	<ul style="list-style-type: none"> Contact local distributor.
Defective O ₂ sensor.	<ul style="list-style-type: none"> Contact local distributor.

Problem 12: Condensation occurs on the surface of inner door after decontamination process (For CCL-170 and CCL-240 units)

Possible Cause	Corrective Actions
Sampling port on inner door is not installed or capped.	<ul style="list-style-type: none"> Ensure the sampling port is capped.
Leakage through magnetic gasket on outer door.	<ul style="list-style-type: none"> Check to make sure outer door can close fully and no gap. If there is gap and cannot be closed properly, check that magnetic strength is not diminished and PVC gasket profile is not deformed. Otherwise, replace with new magnetic gasket.
Decontamination pump failed.	<ul style="list-style-type: none"> Contact local distributor.
Filtered air exchange not working or not installed.	<ul style="list-style-type: none"> Check whether filtered air exchange is installed. There is a short tubing with a 1 µm filter attached to the access port located at the back of the chamber. Check that filter is not saturated and tubing is not blocked. Remove the ULPA filter and make sure the tube is connected to the hole in the blower intake, above where the ULPA filter is mounted. Check also if 2nd filter is not saturated and tubing is not blocked. Loosen the 2 thumb screws at the front of the top duct and lower the top duct carefully. Check if the tubing is secured at the top of the chamber and tubing is not blocked. Re-secure any loose tubing connection and close the top duct.

Problem 13: Garbled or missing characters on LCD module

Possible Cause	Corrective Actions
Display intermittently not stable	<ul style="list-style-type: none"> Press the MENU key twice and see if the display returns to normal. If it returns to normal and is not occurring again then it is caused by intermittent electrical noise. Check the line cord grounding.
LCD Module faulty.	<ul style="list-style-type: none"> If the garbled characters occur again on the same position and missing characters are exactly same as before, then the LCD module is faulty. Contact local distributor.

Problem 14: Buzzer has no sound

Possible Cause	Corrective Actions
Buzzer is disabled.	<ul style="list-style-type: none"> Go to ADMIN menu and choose AUDIBLE ALARM to enable the alarm.
Buzzer spoiled.	<ul style="list-style-type: none"> Contact local distributor.

Problem 15: “Memory 90% full” alarm/reminder displayed on LCD

Possible Cause	Corrective Actions
Memory used already reached 90% of available storage data capacity	<ul style="list-style-type: none"> Go to MENU and choose DATALOGGING. The ERASE ALL LOG allows the user to delete the data logs. Before deleting all logs, make sure that all important logs are exported and stored safely on your computer. Press SET to erase data logs and press MENU to cancel the deletion of the data logs. <div style="text-align: center; margin-top: 10px;"> <pre> graph LR A[MENU] --> B[DATALOGGING] B --> C[ERASE ALL LOG] C --> D[SET TO ERASE] C --> E[MENU TO CANCEL] </pre> </div>

Problem 16: Incubator have a severe condensation on glass door and inside chamber during cooling mode

Possible Cause	Corrective Actions
Water pan inside chamber	<ul style="list-style-type: none"> Take out or dry out the water pan.

Problem 17: Incubator cannot reach temperature 8°C below ambient during cooling mode (CCL-P model)

Possible Cause	Corrective Actions
Water pan filled with water	<ul style="list-style-type: none"> Remove water pan from the chamber, remove top duct during cooling mode.
Temperature ambient is too high. Room air conditioning is OFF	<ul style="list-style-type: none"> Turn on air conditioning. Set temperature ambient minus 6-8 above set point. (If incubator set point is 15°C, so the ambient temperature should be 23°C-24°C)
Cooling control malfunction	<ul style="list-style-type: none"> Go to TEST MODE, choose O2 VALVE2. Press ON and OFF to check the function. See the respond of temperature display decrease gradually, Contact local distributor if the temperature is not responding and decreasing Hear the sound of the cooling module running, otherwise contact local distributor.
Defective Peltier cooling module	<ul style="list-style-type: none"> Contact local distributor.

Problem 18: Incubator have severe condensation during cooling mode (CCL-P model)

Possible Cause	Corrective Actions
Water pan filled with water	<ul style="list-style-type: none"> Remove and take out water pan when unit in cooling operation mode. Open glass door regularly to balance and clip the humidity. Contact local distributor if problem persists.

Problem 19: CO₂ is not injected, display shows 0.0% or % CO₂ display not responding

Possible Cause	Corrective Actions
Defective CO ₂ inject valve	<ul style="list-style-type: none"> Change CO₂ valve, otherwise contact local distributor.
Defective valve channel from I-series mainboard	<ul style="list-style-type: none"> Change mainboard, otherwise contact local distributor.

Problem 20: CO₂ TANK LOW alarm displayed on display

Possible Cause	Corrective Actions
Pressure switch on both CO ₂ tanks indicate low pressure.	<ul style="list-style-type: none"> Check the CO₂ supply and CO₂ tank. Change the tank if empty.

Problem 21: O₂ is not injected, display shows 0.0% or % O₂ display not responding

Possible Cause	Corrective Actions
Defective N ₂ inject valve	<ul style="list-style-type: none"> • Change N₂ valve, otherwise contact local distributor.
Defective valve channel from I-series mainboard	<ul style="list-style-type: none"> • Change mainboard, otherwise contact local distributor.
The tubing connected to N ₂ is bent	<ul style="list-style-type: none"> • Do correction for tubing

Problem 22: ULPA Filter reminder

Possible Cause	Corrective Actions
System predicts filter run hour time and needs to change the filter	<ul style="list-style-type: none"> • Change into new filter and key in to the system the new filter. • To clear the alarm, key in to the system new ULPA filter by access ADMIN menu. SET ULPA REMINDER—Key in 12 months

Problem 23: UV Lamp does not turn on

Possible Cause	Corrective Actions
Door is open	<ul style="list-style-type: none"> • Make sure that the door is fully closed and that the door is firmly pressed onto the door switch.
Busted UV Lamp	<ul style="list-style-type: none"> • Contact local distributor.

Problem 24: UV Lamp is always on

Possible Cause	Corrective Actions
Defective UV relay	<ul style="list-style-type: none"> • Replace mainboard

Problem 25: Outer door is not aligned to the main body

Possible Cause	Corrective Actions
Gap in the upper hinge	<ul style="list-style-type: none"> • Place a foam between the lower part of main door and its main body, then push the outer door at the upper portion.
Gap in the lower hinge	<ul style="list-style-type: none"> • Place a foam between the upper part of main door and its main body, then push the outer door at the lower portion.
Defective door hinge	<ul style="list-style-type: none"> • Replace old ceramic hinges (now obsolete). • Contact local distributor for the new stainless-steel hinges. • When replacing with new hinges, put foam at the bottom of the door assuring that outer door is aligned to main body.

Chapter 7 – Technical Specifications

MODEL		CCL-050_-	CCL-170_-	CCL-240_-
Temperature				
Temp. Control Method		Direct Heat and Air Jacket Using Microcontroller PI		
Ambient Temp. Range*		18°C - 32°C (64.4°F – 89.6°F)		
Temp. Control Range, °C*		Ambient +5 to 60		
Temp. Uniformity, °C*		<± 0.5		
Temp. Accuracy, °C*		<± 0.1		
Temp. Recovery Time** (after 30 seconds door opening, 98% from initial value)		≤5 minutes	≤5 minutes	≤6 minutes
CO₂				
CO ₂ Control System		Microcontroller PI		
CO ₂ Control Range, % CO ₂		0-19.5		
CO ₂ Accuracy, % CO ₂ ***		± 0.1		
CO ₂ Sensor		Infrared (IR) CO ₂ Sensor		
CO ₂ Recovery Time**** (after 30 seconds door opening, 98% from initial value)		Standard unit: ≤6 minutes Suppressed O ₂ model: ≤8 mins.	Standard unit: ≤5 minutes Suppressed O ₂ model: ≤6 mins.	Standard unit: ≤6 minutes Suppressed O ₂ model: ≤10 mins.
O₂ (For Models with Suppressed O₂ Control)				
O ₂ Control System		Microcontroller PI		
O ₂ Control Range, % O ₂		1-18		
O ₂ Accuracy % O ₂ *****		± 0.1		
O ₂ Sensor		Zirconium dioxide sensor type		
O ₂ Recovery Time***** (after 30 seconds door opening, 98% from initial value)		At 5.0% O ₂ by volume: ≤10 mins.	At 5.0% O ₂ by volume: ≤14 mins.	At 5.0% O ₂ by volume: ≤20 mins.
Humidity				
Humidification Method		Water pan		
Humidity Range*****, % RH		85-90		
Physical Construction				
Interior Volume		50 L (1.8 ft ³)	170 L (6 ft ³)	240 L (8.5 ft ³)
External Dimensions (W x D x H)		500 x 500 x 655 mm (19.7" x 19.7" x 25.8")	660 x 660 x 900 mm (26.0" x 26.0" x 35.4")	750 x 770 x 900 mm (29.5" x 30.3" x 35.4")
Internal Dimensions (W x D x H)		345 x 375 x 388 mm (13.6" x 14.8" x 15.3")	505 x 535 x 633 mm (19.9" x 21.1" x 24.9")	595 x 640 x 633 mm (23.4" x 25.2" x 24.9")
Chamber Construction	Main Body	Electrogalvanized steel with Isocide™ antimicrobial coating (except CCL-SS models with stainless steel exterior)		
	Interior Material	Stainless steel, type 304 ((except CCL-Cu models with copper interior chamber)		
	Number of Shelves	3	4	4
	Maximum Number of Shelves	4	7	7
	Shelves Dimensions (W x D x H)	305 x 340 x 16 mm (12.0" x 13.39 x 0.63")	470 x 476 x 16 mm (18.5" x 18.75" x 0.63")	560 x 585 x 16 mm (22.0" x 23.9" x 0.63")
	Maximum Load per Shelf	4 kg/shelf (8.8 lbs/shelf)	11 kg/shelf (24.3 lbs/shelf)	15 kg/shelf (33.1 lbs/shelf)
Electrical Configuration (110-130 VAC, 50/60 Hz)	Nominal Power at 37°C	40.9 W	42.2 W	42.2 W
	Max. Power Consumption	675.5 W	1184.3 W	1727.9 W
	Full Load Amps	5.3 A	9.2 A	13.4 A
Electrical Configuration (220-240 VAC, 50/60 Hz)	Nominal Power at 37°C	40.9 W	42.2 W	42.2 W
	Max. Power Consumption	598.8 W	1008.9 W	1270 W
	Full Load Amps	2.5 A	4.2 A	6.5 A
Net Weight		52 kg (114.6 lbs)	101 kg (222.7 lbs)	121 kg (266.8 lbs)
Shipping Weight (W x D x H)		70 kg (154.3 lbs)	120 kg (264.6 lbs)	155 kg (341.7 lbs)
Shipping Dimensions (W x D x H)		660 x 650 x 900 mm (26.0" x 25.6" x 35.4")	850 x 720 x 1120 mm (33.5" x 28.3" x 44.1")	850 x 850 x 1120 mm (33.5" x 33.5" x 44.1")
Shipping Volume		0.39 m ³ (13.7 ft ³)	0.70 m ³ (24.85 ft ³)	0.79 m ³ (28.03 ft ³)
Contamination Control				
Contamination Control Methods		1) Main body is electro-galvanized steel with Isocide™ antimicrobial coating; 2) 90°C moist heat OVERNIGHT decontamination cycle (HPA validated); 3) ULPA filter***** 4) 0.2-micron inlet filter for gas inputs; 5) 1-micron air circulation filter 6) Optional copper chamber and shelves		

All data recorded is specified for standard models with unloaded chambers and tested under optimum factory setting conditions of 23°C and 60% ambient humidity.

*Results are achieved when tested at 37°C as set point. Results may vary if set point changes and calibration is needed.

**For temperature not exceeding 37.2°C.

***Results are achieved when tested at 5% CO₂ as set point. Results may vary if set point changes and calibration is needed.

****For CO₂ level not exceeding 5.2%.

*****Results are achieved when tested at 5% O₂ as set point. Results may vary if set point changes and calibration is needed.

***** For O₂ level not lower than 4.8%.

***** Esco does not guarantee condensation-free chamber at humidity level higher than 90%.

***** Not available for 50 L models.

APPENDIX

