

Thank you for purchasing this Esco Biological Safety Cabinet. Please read this manual thoroughly to familiarize yourself with the many unique features and exciting innovations we have built into your new equipment. Esco provides many other resources at our website, www.escolifesciences.com, to complement this manual and help you enjoy many years of productive and safe use of your Esco products.



**For Technical Service, contact
North America**

*Esco Technologies, Inc.
903 Sheehy Drive, Suite F, Horsham, Pennsylvania 19044, USA
Toll-Free USA and Canada 1-877-479-3726 • Tel 215-441-9661
Fax 484-698-7757 eti.admin@escolifesciences.com
www.escolifesciences.us*

Rest of the World

*Esco Micro Pte. Ltd.
21 Changi South Street 1 • Singapore 486777
Tel +65 6542 0833 • Fax +65 6542 6920
www.escolifesciences.com • mail@escolifesciences.com*

USER MANUAL

**Airstream® NS G4 Class II Type A2
Biological Safety Cabinet**

Copyright Information

© Copyright 2024 Esco Micro Pte. Ltd. All rights reserved.

The information contained in this manual and the accompanying product is copyrighted and all rights are reserved by Esco.

Esco reserves the right to make periodic minor design changes without obligation to notify any person or entity of such change.

Labculture® and Airstream® are registered trademarks of Esco.

“Material in this manual is provided for information purposes only. The contents and the product described in this manual (including any appendix, addendum, attachment, or inclusion), are subject to change without notice. Esco makes no representations or warranties as to the accuracy of the information contained in this manual. In no event shall Esco be held liable for any damages, direct or consequential, arising out of or related to the use of this manual.”

Table of Contents

Warranty Terms and Conditions.....	5
Introduction	7
1. Product Covered	7
2. Safety Warning	7
3. Document Management.....	7
4. Limitation of Liability	8
5. European Union Directive on WEEE	8
6. Symbols.....	8
Declaration of Conformity	9
Declaration of Conformity	10
Chapter 1 – Product Information.....	11
1.1. About Biological Safety Cabinets (BSCs)	11
1.2. Quick View.....	11
1.3. Unit Identification Labels	12
1.4. Airflow Pattern	12
1.5. Certification	13
1.6. Further Information	13
Chapter 2 – Installation.....	14
2.1. General Requirement.....	14
2.1.1 Location Requirements.....	14
2.1.2 Preparing for Installation.....	15
2.1.3 Electrical Requirements.....	16
2.1.4 Safety Guidelines for Disconnection Power	17
2.1.5 Service Line Requirements	17
2.2. Unpacking and Moving your Cabinet.....	17
2.3. Installation.....	19
2.3.1 Optional Drain Valve Installation.....	19
2.4. Performance Validation/Certification	20
Chapter 3 – Centurion Touchscreen System	21
3.1 Operation	21
3.1.1 Quick Tour.....	21
3.1.2 Main Screen.....	23
3.1.3 Warming Up Condition	25

3.1.4	Normal Operation Mode	26
3.1.5	Standby Mode	26
3.1.6	Alarms and Warnings.....	26
3.2	Menu Options.....	30
3.2.1.	Operator	31
3.3	Diagnostic Mode	34
3.4	Additional Features	36
Chapter 4 – Basic Cabinet Operation.....		39
4.1	Sash Window Operation.....	39
4.1.1	Sash Window State	39
4.1.2	Operating Motorized Sash Window (Only for BSC with Motorized Sash Window)	39
4.1.3	Using Sash Window	40
4.2	Starting and Shutting Down the BSC.....	40
4.2.1	Turning on the BSC	40
4.2.2	Shutting Down the BSC.....	40
4.3	Working in the BSC.....	41
4.4	Working Ergonomics	42
4.5	UV Lamp (If Present)	42
4.6	Decontamination and Disinfecting Agent	43
4.7	Gaseous Decontamination	45
4.7.1	Formalin/Paraformaldehyde Decontamination	45
4.7.2	Chlorine Dioxide Decontamination	46
4.7.3	Hydrogen Peroxide Decontamination	46
4.8	Further Information	48
Chapter 5 – Service and Maintenance.....		49
5.1	Scheduled Maintenance.....	49
5.2	Maintenance/Service Log.....	51

Warranty Terms and Conditions

Esco products come with a limited warranty. The warranty period will vary depending on the product purchased, beginning on the date of shipment from any Esco international warehousing location. To determine which warranty applies to your product, refer to the appendix below.

Esco's limited warranty covers defects in materials and workmanship. Esco's liability under this limited warranty shall be, at our option, to repair or replace any defective parts of the equipment, provided that these parts, if proven to the satisfaction of Esco, were defective at the time of being sold and that all defective parts shall be returned, properly identified with a Return Authorization.

This limited warranty covers parts only, and not transportation/insurance charges.

This limited warranty does not cover:

- Freight or installation (inside delivery handling) damage. If your product was damaged in transit, you must file a claim directly with the freight carrier.
- Products with missing or defaced serial numbers.
- Products for which Esco has not received payment.
- Problems that result from:
 - External causes such as accident, abuse, misuse, problems with electrical power, improper operating environmental conditions.
 - Servicing not authorized by Esco.
 - Usage that is not in accordance with product instructions.
 - Failure to follow the product instructions.
 - Failure to perform preventive maintenance.
 - Using accessories, parts, or components not supplied by Esco.
 - Damage by fire, floods, or acts of God.
 - Customer modifications to the product.
- Consumables such as filters (HEPA, ULPA, carbon, pre-filters) and LED lamp / UV bulbs.
- Esco is not liable for any damage incurred on the objects used on or stored in Esco equipment. Users are advised to conduct a risk assessment and add safety protocols based on their application and sample.

A factory-installed, customer specified equipment or accessories are warranted only to the extent guaranteed by the original manufacturer. The customer agrees that in relation to these products purchased through Esco, our limited warranty shall not apply and the original manufacturer's warranty shall be the sole warranty in respect of these products. The customer shall utilize that warranty for the support of such products and in any event not look to Esco for such warranty support.

Esco encourages all users to register their equipment online at <https://www.escolifesciences.com/services/warranty-registration> or complete the warranty registration form included with each product.

ALL EXPRESS AND IMPLIED WARRANTIES FOR THE PRODUCT, INCLUDING BUT NOT LIMITED TO ANY IMPLIED WARRANTIES AND CONDITIONS OF MERCHANTABILITY AND FITNESS FOR A PARTICULAR PURPOSE ARE LIMITED IN TIME TO THE TERM OF THIS LIMITED WARRANTY. NO WARRANTIES, WHETHER EXPRESS OR IMPLIED, WILL APPLY AFTER THE LIMITED WARRANTY PERIOD HAS EXPIRED. ESCO DOES NOT ACCEPT LIABILITY BEYOND THE REMEDIES PROVIDED FOR IN THIS LIMITED WARRANTY OR FOR SPECIAL, INDIRECT, CONSEQUENTIAL OR INCIDENTAL DAMAGES, INCLUDING, WITHOUT LIMITATION, ANY LIABILITY FOR THIRD-PARTY CLAIMS AGAINST YOU FOR DAMAGES, FOR PRODUCTS NOT BEING AVAILABLE FOR USE, OR FOR LOST WORK. ESCO'S LIABILITY WILL BE NO MORE THAN THE AMOUNT YOU PAID FOR THE PRODUCT THAT IS THE SUBJECT OF A CLAIM. THIS IS THE MAXIMUM AMOUNT FOR WHICH ESCO IS RESPONSIBLE.

These Terms and Conditions shall be governed by and construed in accordance with the laws of Singapore and shall be subject to the exclusive jurisdiction of the courts of Singapore.

Technical Support, Warranty Service Contacts

USA: 1 215-441-9661

Singapore: +65 6542 0833

Global Email Helpdesk: support@escolifesciences.com

Visit <https://www.escolifesciences.com/> to talk to a Live Support Representative

Distributors are encouraged to visit the Distributor Intranet for self-help materials.

Product Appendix, Warranty Service Contacts

Biological Safety Cabinets, Laminar Flow Cabinets, Laboratory Animal Research Workstations, HEPA-Filtered Cabinets (except Streamline brand)	3 years limited
--	-----------------

Note: The warranty periods may vary by country. Contact your local distributor for specific warranty details.

For international distributors, the warranty period starts two months from the date the equipment is shipped from the Esco facility. This allows shipping time so the warranty will go into effect at approximately the same time the equipment is delivered to the user. The warranty protection extends to any subsequent owner during the warranty period. Distributors who stock Esco equipment are allowed an additional four months for delivery and installation, providing the product is registered with Esco. Users can register their products online at <https://www.escolifesciences.com/services/warranty> or complete the warranty registration form included with each product.

Policy updated on 1st January 2015 (This limited warranty policy applies to products purchased on and after 1st January 2015)

Introduction

1. Product Covered

Esco Class II Biological Safety Cabinet					
Model	Electrical Rating	0.9 meters (3 feet)	1.2 meters (4 feet)	1.5 meters (5 feet)	1.8 Meters (6 feet)
Airstream®	220-240 VAC, 50/60 Hz, 1 Φ	AC2-3S8-NS G4 8"	AC2-4S8-NS G4 8"	AC2-5S8-NS G4 8"	AC2-6S8-NS G4 8"
		AC2-3S8-NS G4 10"	AC2-4S8-NS G4 10"	AC2-5S8-NS G4 10"	AC2-6S8-NS G4 10"
		AC2-3E8-NS G4 8"	AC2-4E8-NS G4 8"	AC2-5E8-NS G4 8"	AC2-6E8-NS G4 8"
		AC2-3E8-NS G4 10"	AC2-4E8-NS G4 10"	AC2-5E8-NS G4 10"	AC2-6E8-NS G4 10"
	110-130 VAC, 50/60 Hz, 1 Φ	AC2-3S9-NS G4 8"	AC2-4S9-NS G4 8"	AC2-5S9-NS G4 8"	AC2-6S9-NS G4 8"
		AC2-3S9-NS G4 10"	AC2-4S9-NS G4 10"	AC2-5S9-NS G4 10"	AC2-6S9-NS G4 10"
		AC2-3E9-NS G4 8"	AC2-4E9-NS G4 8"	AC2-5E9-NS G4 8"	AC2-6E9-NS G4 8"
		AC2-3E9-NS G4 10"	AC2-4E9-NS G4 10"	AC2-5E9-NS G4 10"	AC2-6E9-NS G4 10"
	100 VAC, 50/60 Hz, 1 Φ	AC2-3Y7 G4 8"	AC2-4Y7 G4 8"	AC2-5Y7 G4 8"	AC2-6Y7 G4 8"
		AC2-3Y7 G4 10"	AC2-4Y7 G4 10"	AC2-5Y7 G4 10"	AC2-6Y7 G4 10"
		AC2-3N7 G4 8"	AC2-4N7 G4 8"	AC2-5N7 G4 8"	AC2-6N7 G4 8"
		AC2-3N7 G4 10"	AC2-4N7 G4 10"	AC2-5N7 G4 10"	AC2-6N7 G4 10"
AC2-3J7 G4 8"		AC2-4J7 G4 8"	AC2-5J7 G4 8"	AC2-6J7 G4 8"	
AC2-3J7 G4 10"		AC2-4J7 G4 10"	AC2-5J7 G4 10"	AC2-6J7 G4 10"	

2. Safety Warning

- Anyone working with, on or around this equipment should read this manual. Failure to read, understand and comply with the instructions are given in this manual may result in damage to the unit, injury to operating personnel, and/or poor equipment performance.
- Any internal adjustment, modification or maintenance to this equipment must be undertaken by qualified service personnel.
- The use of any hazardous materials in this equipment must be monitored by an industrial hygienist, safety officer or some other suitably qualified individuals.
- Explosive or inflammable substances should never be used in the cabinet unless the adequate risk assessment has been carried out.
- If chemical, radiological or other non-microbiological hazards are being used in the cabinet, additional protective measures should be taken based on an adequate risk assessment.
- This cabinet should not be used with cytotoxic substances unless it has been determined that the filter can be safely changed. Please note that cytotoxic substances cannot be inactivated by the conventional gaseous decontamination method (e.g. formaldehyde) used to inactivate biological agents.
- The biological hazard symbol on the front panel of the cabinet indicates the presence of biological substances that pose a threat to human health.
- Before you process, you should thoroughly understand the installation procedures and take note of the environmental/electrical requirements.
- In this manual, important safety-related points will be marked with the symbol. 
- If the equipment is used in a manner not specified by this manual, the protection provided by this equipment may be impaired.

3. Document Management

We recommend that you keep this manual, along with the factory test report close to the cabinet for easy reference by the cabinet operator and qualified maintenance personnel.

If you require replacements for any of the provided documentation (including factory test reports) you can request copies from Esco Customer Services*. Please provide the following information when making requests for replacement documents:

- Company (Organization) Name

- Product Brand and Model
- Product Serial Number
- Documents requested

* There may be a nominal charge for this service.

4. Limitation of Liability

The disposal and/or emission of substances used in connection with this equipment may be governed by various local regulations. Familiarization and compliance with any such regulations are the sole responsibility of the users. Esco's liability is limited with respect to user compliance with such regulations.

5. European Union Directive on WEEE



- **Directive 2012/19/EU on Waste Electrical and Electronic Equipment (WEEE)**

This product is required to comply with the European Union's Waste Electrical & Electronic Equipment (WEEE) Directive 2012/19/EU. It is marked with the following symbol:

Esco sells products through distributors throughout Europe. Contact your local Esco distributor for recycling/disposal.

The recommended method of disposal is according to The Federal, State and Local Government regulations.

6. Symbols

Information in this manual may be prefaced with the following symbols. They are provided to help you identify important operational, safety, maintenance or conformance issues.



Electrical Hazard: Danger of electric shock



Turn Off and Disconnect From Main Supply Before Proceeding: Do not perform this operation while the unit is operational



The Biohazard Symbol on the front panel of the cabinet indicates the presence of biological substances that pose a threat to human health



Approved Service Engineer Only: Operation to be performed only by approving engineers

Declaration of Conformity

In accordance with EN ISO/IEC 17050-1:2010

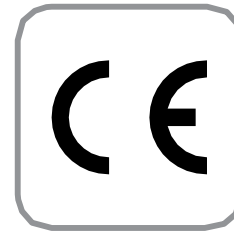

We, Esco Micro Pte. Ltd.
Of 21 Changi South Street 1
Singapore, 486777
Tel: +65 6542 0833

Declare on our sole responsibility that the product:

Category : Class II Type A2 Biological Safety Cabinet
Brand : Airstream
Model : AC2-3S8-NS G4 8", AC2-3S8-NS G4 10", AC2-4S8-NS 8", AC2-4S8-NS G4 10", AC2-5S8-NS G4 8", AC2-5S8-NS G4 10", AC2-6S8-NS G4 8", AC2-6S8-NS G4 10", AC2-3E8-NS 8", AC2-3E8-NS G4 10", AC2-4E8-NS G4 8", AC2-4E8-NS G4 10", AC2-5E8-NS G4 8", AC2-5E8-NS G4 10", AC2-6E8-NS G4 8", AC2-6E8-NS G4 10".

In accordance with the following directives:

2014/35/EU : The Low Voltage Directive and its amending directives
2014/30/EU : The Electromagnetic Compatibility Directive and its amending directives

Has been certified independently to comply with the requirement of the following Harmonized Standards:

Safety : IEC 61010-1:2010
EMC : EN 61326-1:2021
Design/Performance Criteria : NSF/ANSI 49 Class II Biological Safety Cabinet

More information may be obtained from Esco Lifesciences' authorized distributors located within the European Union. A list of these parties and their contact information is available upon request.

Place of Issue: Singapore
Date of Issue: March 2023

Indra Setiawan

Indra Setiawan
Plant Manager, Esco Lifesciences

This Declaration of Conformity is only applicable for 230V AC 50 Hz units

Declaration of Conformity

In accordance with EN ISO/IEC 17050-1:2010



We, Esco Micro Pte. Ltd.
Of 21 Changi South Street 1
Singapore, 486777
Tel: +65 6542 0833

Declare on our sole responsibility that the product:

Category : Class II Type A2 Biological Safety Cabinet
Brand : Airstream
Model : AC2-3S8-NS G4 8", AC2-3S8-NS G4 10", AC2-4S8-NS 8", AC2-4S8-NS G4 10", AC2-5S8-NS G4 8", AC2-5S8-NS G4 10", AC2-6S8-NS G4 8", AC2-6S8-NS G4 10", AC2-3E8-NS 8", AC2-3E8-NS G4 10", AC2-4E8-NS G4 8", AC2-4E8-NS G4 10", AC2-5E8-NS G4 8", AC2-5E8-NS G4 10", AC2-6E8-NS G4 8", AC2-6E8-NS G4 10".

In accordance with the following directives:

Electrical Equipment (Safety) Regulations 2016
The Electromagnetic Compatibility Regulations 2016

Has been certified independently to comply with the requirement of the following Harmonized Standards:

Safety : IEC 61010-1:2010
EMC : EN 61326-1:2021
Design/Performance Criteria : NSF/ANSI 49 Class II Biological Safety Cabinet

More information may be obtained from Esco Lifesciences's authorized distributors/local offices. A list of these parties and their contact information is available upon request.

Place of Issue: Singapore

Date of Issue: March 2023

Indra Setiawan

Indra Setiawan
Plant Manager, Esco Lifesciences

This Declaration of Conformity is only applicable for 230V AC 50 Hz units

Chapter 1 – Product Information

1.1. About Biological Safety Cabinets (BSCs)

Biological safety cabinet plays a significant role in any laboratories that handle biological materials. It is a primary containment device that is designed to protect the operator and environment from biological hazards that would otherwise pose a threat to human life and the environment. Class II Biological Safety Cabinet is additionally designed to provide product protection to eliminate or at least minimize the product contamination from outside contaminants or from cross-contamination of products worked on inside the work zone.

We encourage you to learn more about the functions and operating principles of your biological safety cabinet. We also further encourage you to conduct a risk assessment on your work with your safety professional to determine the biological safety cabinet you require. The information below is provided to help you with your risk assessment.

1.2. Quick View

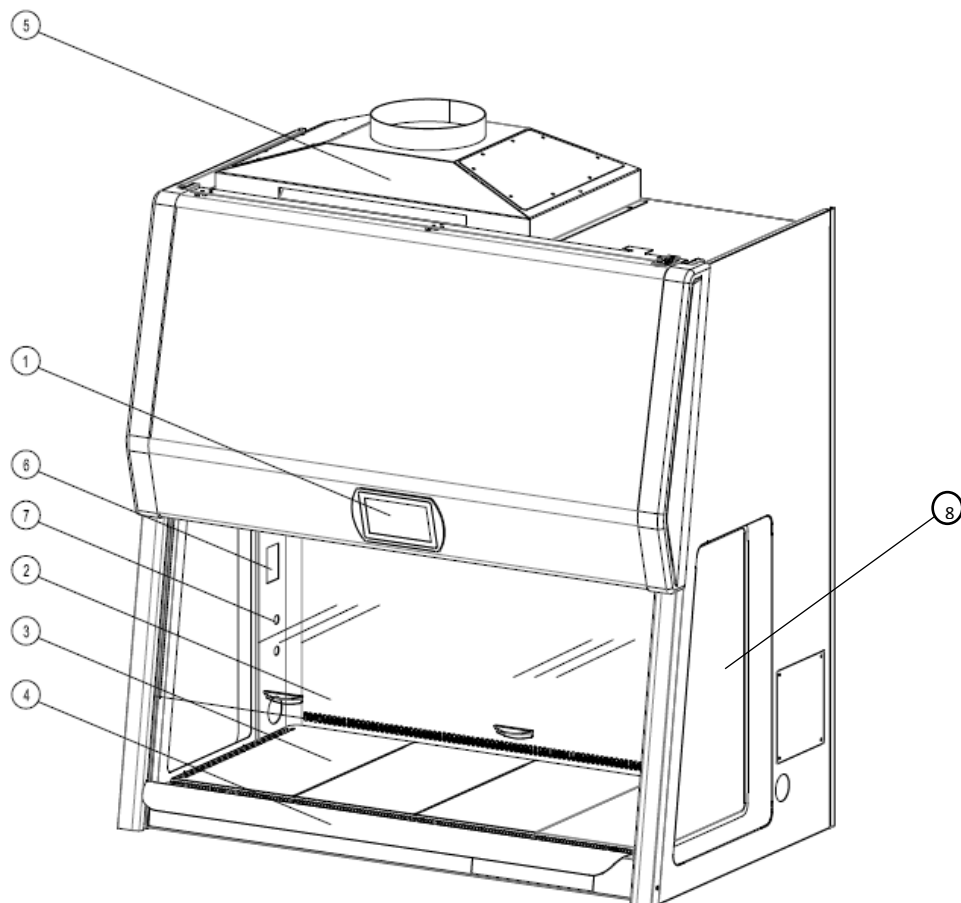

Figure 1. Quick View of AC2-NS G4

- | | |
|--------------------------------------|--|
| 1. Esco Centurion Touchscreen System | 5. Exhaust Collar (optional) |
| 2. Sash Window | 6. Electrical Outlet (Optional) |
| 3. Interior Work Area | 7. Service Fixture Provision (Optional) |
| 4. Armrest | 8. Side Glass Wall (for –E series cabinet) |

1.3. Unit Identification Labels

1. Cabinet Power Inlet

Located on the front right top cabinet, this label contains the electrical requirement needed to operate the unit.

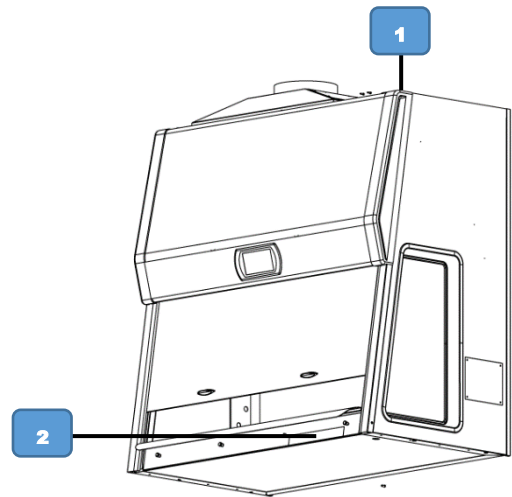
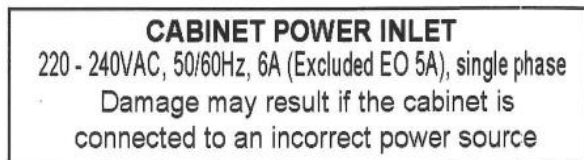

2. Unit Information and Manufacturer Sticker Label

This label contains Model, Serial Number, Working Opening, Power, Manufacturer, Inflow, and Downflow.



Class II Type A2 BSC per NSF/ANSI 49
Model : AC2-4E9-NS G4 10"
Serial Number : 2021-160664
Working Opening : 10 inches
Maximum Power : 889W
Full Load Amps : 10.7A
Nominal Power : 200W
 110-130VAC, 50/60Hz, 1PH

Cabinet Airflow Setpoints:
INFLOW: 105 fpm ± 5 fpm for DIM. Secondary Methods (SM): Remove Armrest, Cover small gap between the front grill/work surface and the cabinet with tape. Mark the probe position on the tape. SM grid: middle of 3 inches opening, 8 points, 5 5/16 inches distance from walls and 5 5/16 inches apart. Use Esco probe holder. Multiply the SM average with correction factor of 0.312 to get inflow.
DOWNFLOW: 60 fpm ± 5 fpm, 3 rows x 7 columns (21 points total).
 L-R: 6 inches from wall & 6 inches apart. F-B: 6 inches from wall & 5 1/2 inches apart.



1.4. Airflow Pattern

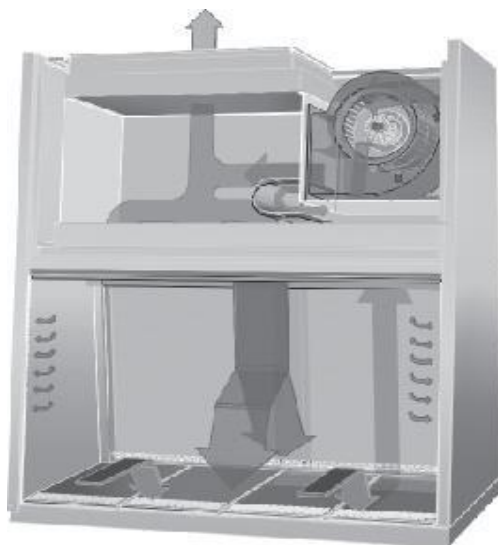

Figure 2. Airflow Pattern of BSC Class II Type A2

- ULPA Filtered Air
- Unfiltered/Potentially Contaminated Air
- Room/Inflow Air

- Ambient air is pulled through the perforations located towards the work zone front to prevent contamination of the work surface and work product. The inflow does not mix with the clean air within the cabinet work zone. Inflow air travels through a return path toward the common air plenum (blower plenum) at the top of the cabinet.
- Approximately 37% of the air in the common plenum is exhausted through the ULPA filter to the room. The remaining 63% of the air is passed through the downflow ULPA filter and into the work area as a vertical laminar flow air stream bathing the work surface in clean air.
- The uniform, non-turbulent air stream protects against cross-contamination within and throughout the work area.
- Near the work surface, the downflow air stream splits with a portion moving toward the front air grille, and the remainder moving to the rear air grille. A small portion of the ULPA filtered downflow enters the intake perforations at the side capture zones at a higher velocity.
- A combination of inflow and downflow air streams forms an air barrier that prevents contaminated room air from entering the work zone and prevents work surface emissions from escaping the work zone.
- Air returns to the common air plenum where the 37% exhaust and 63% recirculation process is continued.

1.5. Certification

Airstream® NS G4 biological safety cabinet is certified to NSF/ANSI 49 Biological Safety Cabinet Standard and the complete list of the certified cabinets is available on the NSF website.

1.6. Further Information

For further information, we have many documents available in our Technical Support Library at www.escolifesciences.com. Here you will find the most up-to-date information in far more details than are possible to include in this manual.

- Shipping
This provides information regarding shipping terms and conditions. Unless otherwise agreed, the Customer is responsible for transportation from the principal place of shipment. Esco shall at the Customer's request and expense arrange carriage and insure the equipment against normal transit risks but in the event of loss or damage whether or not caused by the negligence of Esco or its carrier or any other person, Esco liability shall be limited to passing on to the Customer the benefit of such insurance.
- Biological Safety Cabinet Lifespan
The current lifespan of a Biosafety Cabinet is approximately 15 years. Every Esco cabinet is manufactured as a commercial grade product and Esco provides replacements for consumable elements as well as any components that might fail while the product is in service. Optional and replacement parts can be purchased from your local distributor or contact Esco for more information.

Chapter 2 – Installation

2.1. General Requirement

2.1.1 Location Requirements

The BSC needs to be sited in a location that does not compromise the performance of the unit.

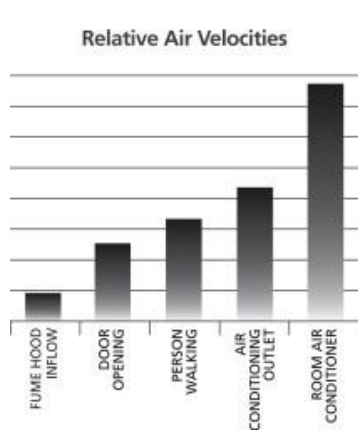

As seen in the chart, your cabinet's internal airflow velocity is relatively low compared to the airflow disturbances potentially caused by opening a door, a person walking by or direct exposure to an air-conditioning outlet. These external airflow disturbances can affect the containment of the BSC. Therefore, the BSC should be located as far away as possible from sources of airflow disturbance and in an orientation that optimally shields the cabinet's airflow from all external airflow disturbances. There should be adequate SOP in place to minimize events that will affect the performance of the cabinets.

The following requirements should be taken into account:

- If necessary, the armrest and sash cover can be removed to reduce the overall depth of the cabinet. Detailed instructions on how to carry out this step can be obtained from your Esco Service Representative.
- Poor siting of a cabinet can adversely affect performance. A specialist engineer and safety personnel in your facility should be consulted on the correct positioning of the cabinet prior to installation.
- Cabinets should never be sited in line with a doorway, a window that can be opened, or adjacent to a thoroughfare. Care should be taken to ensure that the potential effect of room air diffusers, fans, extractors, vents, etc. on the BSC are taken into account and any risk of airflow disturbance is appropriately treated (e.g. eliminated, mitigated) before installation.
- Room air supply diffusers should not be within 1.5 meters (5') of the front aperture. If there are large numbers of cabinets in a laboratory this recommendation may be difficult to comply with, but where diffusers have to be placed in close proximity to a safety cabinet, their discharge velocities should be maintained low.
- The position of a BSC should satisfy the spatial requirements (e.g. vision, lighting, and convenience of access) of the operator and people working nearby. If the cabinet is installed on a benchtop, the leading edge should slightly overhang or properly secure by a flush with the edge of the benchtop.
- There should not be an open space between the leading edge of the cabinet and the front of the bench as this may create turbulence in front of the aperture. It also provides an obstacle that could adversely affect airflow across the cabinet face.

Position Requirements (Based on NSF/ANSI 49:2020)

BSCs should have at least [12 inches (300 mm)] clearance from the filter face and any overhead obstructions when the cabinet is in its final operating position. At least 12 inches (300 mm) clearance is required.

All BSCs should be placed in a laboratory at a location that provides a minimum of:

- 6 inches (150 mm) from adjacent walls or columns.

- 6 inches (150 mm) between two BSCs.
- 6 inches (150 mm) space between both sides of the cabinet and 6 inches (150 mm) behind the BSC to allow for service operations.
- 40 inches (1020 mm) of open space in front of the BSC.
- 60 inches (1520 mm) from opposing walls, benchtops, and areas of occasional traffic.
- 20 inches (510 mm) between BSC and benchtops along a perpendicular wall.
- 100 inches (2540 mm) between two BSCs facing each other.
- 60 inches (1520 mm) from behind a doorway.
- 40 inches (1020 mm) from an adjacent doorway swing side.
- 6 inches (150 mm) from an adjacent doorway hinge side.

2.1.2 Preparing for Installation

- Support Requirements

Esco provides a number of support stand options, these are summarized below and further details can be found in the table at the end of this section. (Note: Some support stands are not NSF certified)

- Fixed height
- Adjustable height
- Telescoping height
- Infinitely adjustable cradle stand



Esco support stand with levelling feet is recommended for safety. It is recommended that the installation of the support stand be carried out by qualified personnel (contact your Esco Distributor for assistance). After the cabinet is installed on the support stand, use a level placed in the center of the work tray to adjust the legs to achieve a level work surface; first level from left to right and then level from front to back. The NSF approved leg levellers provide a maximum 50 mm (2") adjustment.

When installing the cabinet onto an existing work surface, ensure that the structure can safely support the combined weight of the cabinet and any related equipment. Some modifications to the work surface may be necessary. The work surface should be smooth, nonporous and resistant to those disinfectants and chemicals to which the cabinet is regularly exposed to.

- Relocating the Cabinet

⚠ Normally BSCs are rarely moved once they are in their ideal positions, but should there be a need to relocate or repackage the unit, here are some considerations:

- It is recommended that risk assessment is carried out before the BSC is moved.
- Before moving the BSC, remember to decontaminate the cabinet.
- Before moving the BSC, remember to secure all moving parts (e.g. sash window).
- BSC is heavy so please carry out adequate workplace safety assessment before moving the cabinet.

Should only manpower is available (i.e. no suitable equipment), it will usually take 6 or more people to move a BSC manually.

⚠ For repackaging:

- Bolt the BSC to the pallet.
- Strap the BSC body down to the pallet.
- Repackage as necessary. If possible, use the original packaging.
- When moving the BSC, use material handling equipment and lift the pallet.

- **Moving a Permanently Installed BSC**
For existing BSCs with auxiliary equipment, gas, electric and vacuum connections, should be cleared for maintenance by a biosafety professional prior to disassembly. BSCs maybe required to be space decontaminated before the move. After a BSC is moved, it should be certified according to applicable performance standards.

- **Environmental Requirements**
 - Indoor use only.
 - The altitude of up to 2,000 meters (6,600 feet). At altitude more than 2000 meters may require Airflow sensor calibration.
 - Relative humidity between 20% – 90%
 - Temperature between 18 °C – 30 °C (65 °F – 86 °F).
 - Pollution Degree 2.0

Pollution degree describes the amount of conductive pollutants present in an operating environment. In pollution degree 2.0, it is assumed that only non-conductive pollutants such as dust are present, except when occasional conductivity caused by condensation.

- **Exhaust Requirements (Optional)**
The exhaust filter area is susceptible to disruptive air currents or air drafts. A clearance of at least 10 cm (4”) is recommended between the highest point of the cabinet and the ceiling. If the distance is less than 10 cm (4”), the airflow alarm system may need re-calibration. For proper exhaust filter leak scanning purposes, a minimum clearance of 20 cm (8”) is recommended.
 - ⚠ Esco does not guarantee that this distance would be sufficient. It would have to be verified by your nearest Esco distributor or your service company.

If you intend to connect your cabinet to an external exhaust system, Esco offers an optional Exhaust Collar for Thimble-Ducting. Installation requirements and instructions are provided with the Exhaust Collar. (Note: External Exhaust System Installation must be NSF certified).

2.1.3 Electrical Requirements

- The cabinet should be connected to its own dedicated power outlet(s).
- The power rating for each model is shown below. Ensure that the outlet is rated accordingly.

Model	Power Rating
AC2-3S8-NS G4 8" / AC2-3E8-NS G4 8" / AC2-3S8-NS G4 10" / AC2-3E8-NS G4 10" / AC2-4S8-NS G4 8" / AC2-4E8-NS G4 8" / AC2-4S8-NS G4 10" / AC2-4E8-NS G4 10" / AC2-5S8-NS G4 8" / AC2-5E8-NS G4 8" / AC2-5S8-NS G4 10" / AC2-5E8-NS G4 10" / AC2-6S8-NS G4 8" / AC2-6E8-NS G4 8" / AC2-6S8-NS G4 10" / AC2-6E8-NS G4 10"	220 - 240 VAC, 50/60Hz
AC2-3S9-NS G4 8" / AC2-3E9-NS G4 8" / AC2-3S9-NS G4 10" / AC2-3E9-NS G4 10" / AC2-4S9-NS G4 8" / AC2-4E9-NS G4 8" / AC2-4S9-NS G4 10" / AC2-4E9-NS G4 10" / AC2-5S9-NS G4 8" / AC2-5E9-NS G4 8" / AC2-5S9-NS G4 10" / AC2-5E9-NS G4 10" / AC2-6S9-NS G4 8" / AC2-6E9-NS G4 8" / AC2-6S9-NS G4 10" / AC2-6E9-NS G4 10"	110-130 VAC, 50/60Hz

- The maximum combined current draw for all electrical outlets is 5 Amperes. Plugging an equipment that draws more than 5 Amperes such as a vacuum cleaner will blow up the fuse.
- The power inlet is located on the top right side of the cabinet and the cord is 3 m (10 ft.) long. Plug the power cord here and to the wall outlet. When preparing the installation site, try to ensure the outlet is located to the right of the cabinet for ease of access.
- The cabinets maximum voltage fluctuation is +10% of the nominal voltage. The DC-ECM motor

maintains airflow by increasing filter loading when voltage fluctuation is higher. Therefore, equipment such as voltage regulator or UPS is no longer required.

- The cabinet cannot be plugged to GFCI outlet because it will trip the outlet. The cabinet must be plugged to regular, Non-GFCI outlet
- A reliable protective earth connection is recommended for better operation and safety.

2.1.4 Safety Guidelines for Disconnection Power

- A standard cabinet includes two (2) appliance inlets, side by side, located at the top right corner side from the front view of the cabinet. The first appliance inlet (right side) shall supply the main biological safety cabinet. Next to the first inlet, the second appliance inlet (left side) shall provide an internal power supply to electrical outlets inside the biological safety cabinet. Before connecting the unit to the power source, ensure that the cable and plug are free from any damage.
- Once the BSC is properly turned off, unplug both of the dedicated cables attached to the appliance inlet to disconnect the device from the power supply system.

2.1.5 Service Line Requirements

- All service lines should be installed by a suitably qualified and/or certified engineer, in accordance with all applicable local, state and government regulations.
- Service line attachments should be equipped with an emergency shut off valve that can be accessed quickly and with ease, should the need arises.
- Check whether there is a need to install pressure regulators to reduce the line pressure.
- The BSC plumbing inlet was tested at maximum 100 psi according to factory standard.
- Your BSC can accommodate service fixtures on the left or right-hand side of the cabinet. Make allowance for the positioning of service lines when planning the installation site to ensure ease of access to emergency shut off valves.

2.2. Unpacking and Moving your Cabinet

1. Check the packing labels and delivery note before unpacking to ensure the correct consignment has been delivered.
2. Put all packing materials to one side and keep it stored. You may need them to repackage the unit if anything untoward incidence is discovered with the unit during installation.
3. If you have purchased an optional support stand, this shall be attached to the shipping carton of the cabinet.
4. Cut the retaining straps and remove the support stand (if purchased). This will require at least two persons.
5. Carefully remove the shrink wrap from the outside of the main carton and dispose of it.
6. After that, remove the retaining straps and top of the packing carton.
7. Remove the cardboard outer from the unit by sliding it up and over the unit.
8. Remove the shrink wrap from around the polystyrene panels and dispose of carefully.

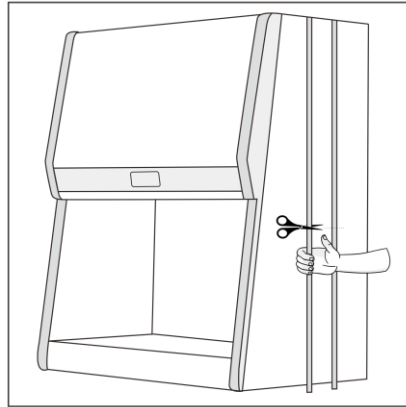

Figure 3. Removing the Strapping

9. Remove all of the polystyrene, cardboard, and Styrofoam packaging materials and place them with the outer carton.
10. Cut the inner shipping straps and remove the large protective plastic bag.
11. There is a protector on the top of the unit (cardboard sheet), remove this before activating the unit.
12. Take out the carton containing the manuals, toolkit and retrofit kits and place safely on one side.
13. Remove the screw on stoppers of sash balancing

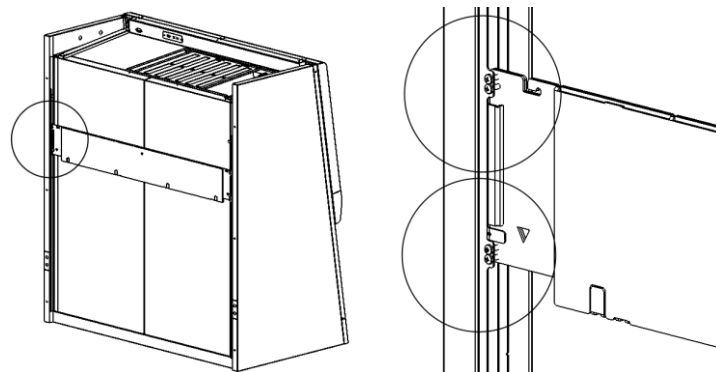

Figure 4. Sash Balancing Stopper

14. Remove the two retaining screws on the side of the front panel. Exercise extreme caution when raising the front panel to avoid possible injury or damage to the cabinet.
15. Open up the housing and remove all of the packing materials inside the panel (remember to replace the locking screws when you close the panel).
16. Remove any available sash supports and work area shipping supports.
17. Remove the protective plastic coating on the stainless steel work trays and armrest.
18. The cabinet may be fastened to the skids on the shipping pallet with two braces – one on each side. If so, unbolt the cabinet from the skids and remove the braces.
19. At this point, you should assemble the stand as per the instructions provided.
20. Using a mechanical lifting truck, the cabinet should be positioned over the stand, the stand offered up to the cabinet and the bolts fastened. After the stand is fastened to the cabinet, lower the assembled unit on the ground slowly.
21. Check all of the bolts have been fastened adequately and then move the cabinet to its final position. The side panel should not be used to lift the cabinet as it is not a structural component. Please lift by means of the back edge or remove the side panels to lift by means

of the side edges. (For information on removing the side panels, please refer to the next chapter).

22. Fasteners securing the armrest – located at the lower side of the frame around the sash window – must be tightly secured.

2.3. Installation

2.3.1 Optional Drain Valve Installation

Connect the drain valve using the supplied PTFE tape and ensure it is turned to the off position.

Warning: Please consult your lab safety manager before installing the drain valve. For safety, the drain valve is not installed in about 95% of the BSCs and not included on Esco BSCs, to prevent some users from inadvertently draining contaminated liquid into a bucket placed under the drain valve. Please contact Esco if you need the drain valve.

If the drain valve is desired, install it according to the diagram below. Use the supplied PTFE tape or Loctite to seal the threads. **Always shut off the drain valve when not in use, to prevent contaminants leak.**

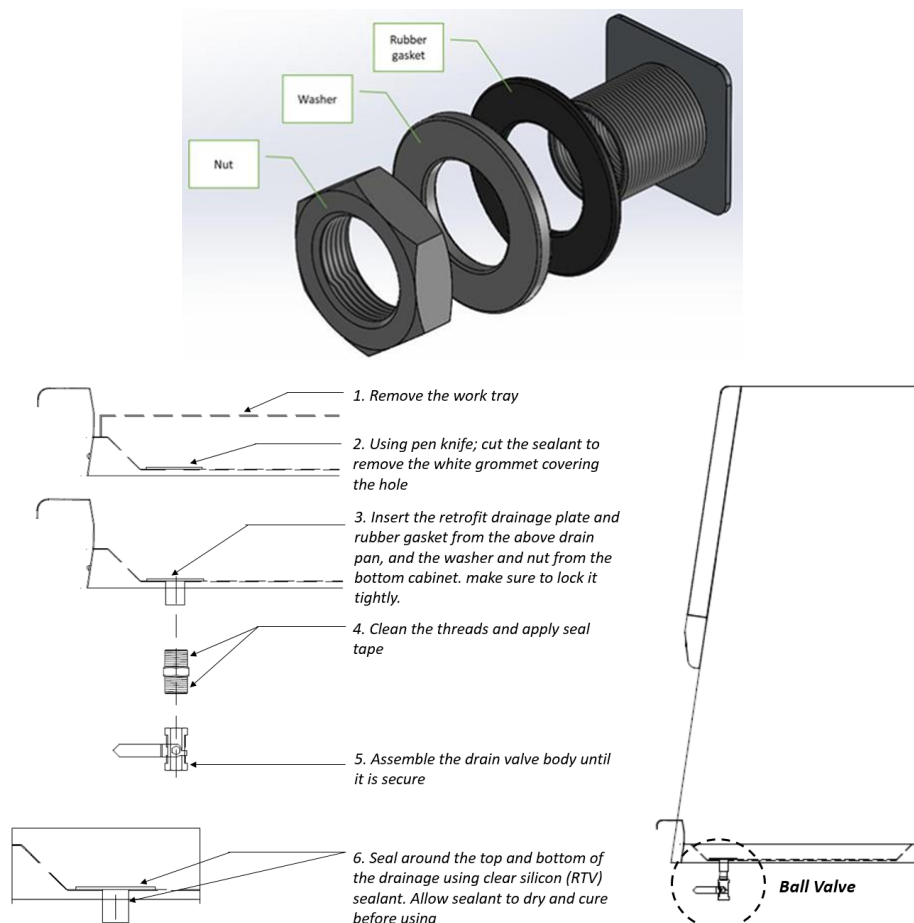

Figure 5. Drain Valve Installation

2.3.2 Connecting the Electrical Supply

1. Please refer to the serial label on the BSC for the proper electrical rating to ensure the BSC is connected to the correct electrical supply.
2. Review the electrical wiring diagrams in the Appendix section prior to installation. All wiring should be done in accordance with the applicable National Electrical Code.

3. Connect the supplied power cord to the input on the top of the BSC. Make sure that the cable connector is seated firmly in the socket.
4. The standard cabinet has one power inlets, located in the upper right corner of the cabinet front view. The inlet serves as the main electricity supplier in the biosafety cabinet. If it is connected, the LCD on the Biosafety cabinet will light up and start the BSC service program.
5. Ensure the main electricity supply is switched off and then plug the unit into the wall socket. Do not start the unit up until all connections have been made and the post-installation steps have been completed.

2.3.3 Connecting the Service Fixture(s)

1. If you have purchased service fixtures for your cabinet these would either have been factory-installed or provided in a package located inside the work tray when you unpacked the cabinet. If the fixtures have been provided for site installation, there will be full instructions provided with them. Please refer to the instructions provided to install your retrofit kits. Connecting the cabinet to service lines must be performed by qualified personnel, in accordance with all applicable local, state and government regulations.
2. Where applicable, each connection should be tested and certified by qualified personnel.
3. Connections to service lines may be subject to the provision of a safety device. There should always be an appropriate emergency shut off valve installed within easy reach of the cabinet operator.

2.3.4 Safety and Warning Labels on the Cabinet

Anyone using the BSC should familiarize themselves with the various labels displayed in and on the cabinet. It is very important that users are familiar with the meanings of the labels before attempting to use the unit.

2.3.5 Preliminary Cleaning

Wipe the interior and exterior of the BSC with water or mild household detergent. The compatibility of the cleaning agent should be verified. Note: When the cabinet has been used for work, other suitable interior cleaning and disinfection method should be applied.

2.4. Performance Validation/Certification

After having installed the cabinet but before starting to use it, cabinet performance must be validated and certified to factory standards. It is recommended that this validation and certification be performed only by qualified personnel who is familiar with the methods and procedures for certifying biological safety cabinets. The testing methods and equipment needed for carrying out the tests are specified on the test report accompanying your cabinet.

2.4.1 Disclaimer

The performance and safety of all Esco BSC are rigorously evaluated at our factory. Regular field certification is important to ensure factory standards are maintained.

2.4.2 References for Qualified Certifiers

- North America
 1. NSF (<https://info.nsf.org/Certified/Biosafety-Certifier/index.asp?standard=0AC>)
 2. Esco (<http://www.escolifesciences.us>)
- UK, Vietnam, the Middle East/North Africa, Indonesia, Korea, Malaysia, Philippines, Singapore. Esco offers field certification services directly. Contact the local Esco office.
- Other Countries
Contact Esco or local distributor

Chapter 3 – Centurion Touchscreen System

3.1 Operation

This section will provide you the information on how to control Airstream® Biological Safety Cabinet from the seven inches screen display mounted perfectly on the front cabinet. The screen display unit measures 7 inches diagonally across and has touch-sensitive areas that support finger gestures like tapping and swiping. The screen works perfectly adjusting the laboratory-gloved user.

3.1.1 Quick Tour

To facilitate user entry into the new technology, a special menu called Quick Tour has been prepared. With our Quick Tour features, users will never feel lost. Just tap on the Iconic Cabinet Symbol and it will guide you through all limitless features. Take a look at each page for a better understanding of our Centurion® Touchscreen.

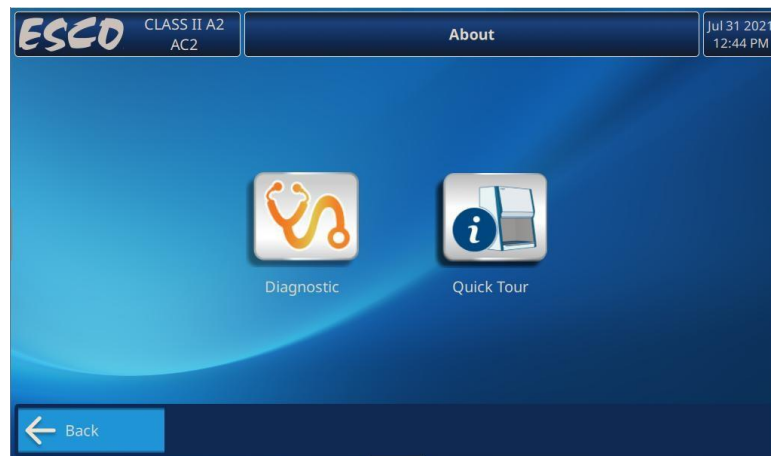

Figure 6. Diagnostic and Quick Tour Features

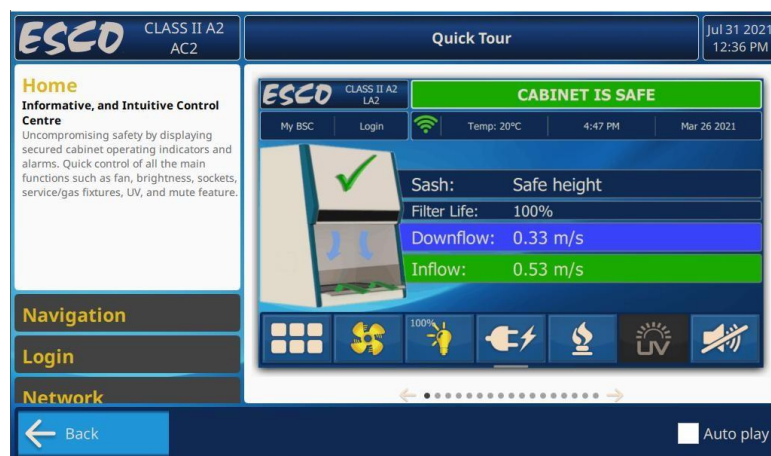

Figure 7. Quick Tour Features

1. Home

Informative, and Intuitive Control Centre

Uncompromising safety by displaying secured cabinet operating indicators and alarms. Quick

control of all the main functions such as fan, brightness, sockets, service/gas fixtures, UV, and mute feature.

2. Navigation

A Smart Touch

Allows users to move pages using some gestures for the fastest way! Swipe Up, Down, Right, and Left to know its functions.

- Swipe Up from Bottom edge : Go to Homepage
- Swipe Down from Top edge : Lock Screen
- Swipe Left from Right edge : Access Homepage Display
- Swipe Right from Left edge : Access Previous page

3. Login

Manage Your Cabinet Access

Give limited access to your cabinet by applying a username and password. Save username and password for easy login next time.

4. Network

Connect and Update

The network allows the cabinet to update real-time.

5. Remote Modbus

Link to other Devices

Enable user to access the cabinet remotely from other devices such as PC to control the main function with a condition. Allows transferring data log to a PC.

6. Logging

Data Record and Collection Made Easy

Check, delete, or export the data log, alarm log, or event log. Transferring data through Bluetooth or USB.

7. Booking Scheduler

Organize Users Timetable

Define and schedule cabinet usage for multiple users. Register, edit, cancel, delete or export the cabinet usage booking schedule through Bluetooth or USB.

8. Fan & UV Scheduler

Your Regular Assistant

Help to schedule the daily or weekly UV sterilization, turn off and turn on the fan prior and after use automatically

9. Sash Stand By

Save Energy Up to 70%

Move the sash window lower to the stand-by height point and save energy without compromising the product and your safety!

10. Airflow Fail

Ultimate Protection Alarm

Acoustic and visual alarms in any failure of air flows

11. Sash Unsafe

Uncompromising Safety

Acoustic and visual alarms in a false sash window position

3.1.2 Main Screen

The main screen display consists of the Info & Cabinet status area, Main operating parameters of the unit area, and control panel. Red arrows show the purpose of each area on the Main Screen Display.

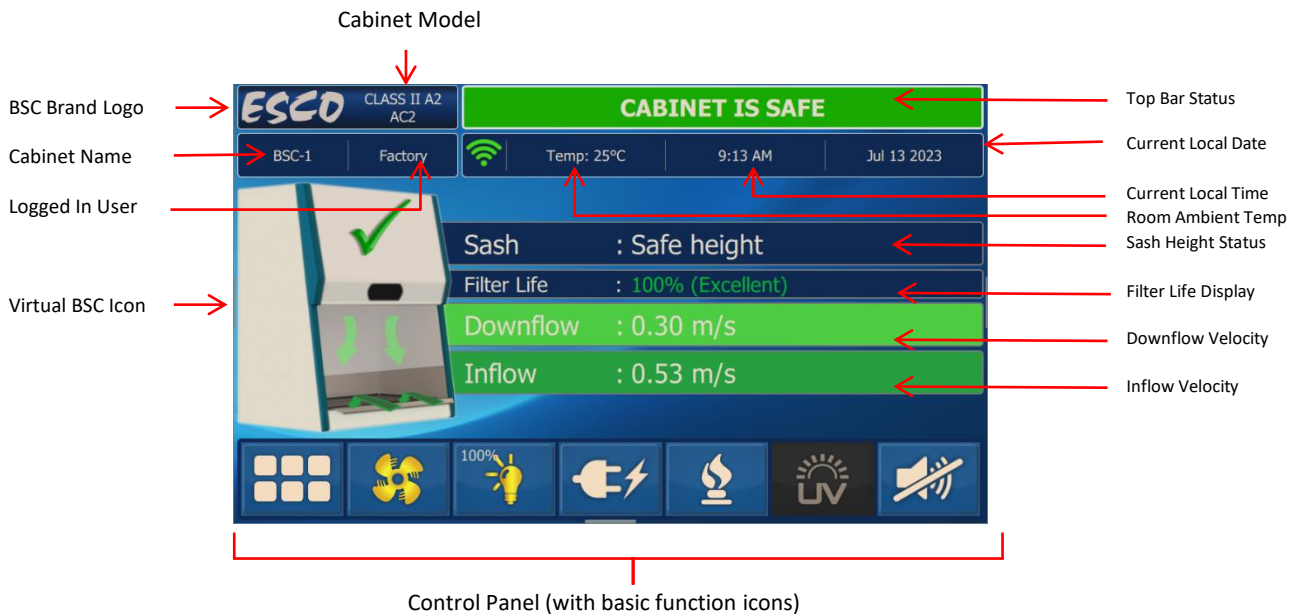

Figure 8. Main Screen Display







- Info & Cabinet status area shows Manufacturer logo, Cabinet model, Cabinet status, Cabinet name, login menu where lock feature with password is, room ambient temperature, and the current local date and time.
- The main operating parameters of the unit consist of airflow velocity, sash height status, up and down icon (for motorized sash), and iconic cabinet symbol with airflow illustration. Cabinet status is in line with cabinet operating parameters where these two areas will change and show hazard information with a visual alarm, followed by an audible alarm.



Figure 9. Main Screen Display for Motorized Sash

- The Control panel area is where the iconic shortcuts for controlling the main function settings can be accessed, such as the menu, blower fan, light, electrical outlet, gas/solenoid valve, UV Lamp, and mute. See table below.

Icon Name	OFF State	ON State	Description
Menu			Icon for open menu
Fan		 Nominal	Icon for turning on/off the internal fan. If Blower PIN has configured, system will ask PIN before executing the command.
		 Standby	Standby speed is only can triggered to activate by moving the sash window to standby height during fan nominal speed. Tap the icon during this condition will turned on the internal fan.
Lamp			Icon for turning on/off the internal Lamp. Tap for toggle state. Tap and hold for dimmable setting.
Electrical Outlet			Icon for turning on/off the Electrical Outlet.
Gas/Solenoid Valve			Icon for turning on/off the Gas/Solenoid Valve.

UV Light			Icon for turning on/off the UV Light.
Alarm Mute			Icon for muted the audible alarm. Tap for muted/unmuted. Tap and hold for open mute timer setting.
Motorize Sash Up			Icon for moving sash window going up. Tap and hold until wanted sash height opening. *Only unit with motorized sash
Motorize Sash Down			Icon for moving sash window going down. Tap and hold until wanted sash height opening. *Only unit with motorized sash

3.1.3 Warming Up Condition

Top Bar Status shows warming up indication including count down time. Warming up condition will happens when the fan is turning on, system needs to stabilize the fan speed and airflow velocity reading. During this condition, airflow velocity are not showing except in Maintenance Mode.



Figure 10. Warming-up Time

During the warm-up period, the user can use the FAN icon to turn off the blower, the LIGHT icon to turn on and off the LED lamp, and the MENU icon. However, to be able to access the menu, the user needs to input their login details and even then, some sections of the menu (WARM-UP and all FIELD CALIBRATION) are still not accessible for the user. Entering the menu during this time will pause the warm-up period.

3.1.4 Normal Operation Mode



Figure 11. Operational Safe Condition

Figure Above shows the unit in normal operation mode, with sash height at the safe position, airflow velocity at the safe operational speeds.

3.1.5 Standby Mode



Figure 12. Standby mode

When selected, Standby Mode reduces the blower speed to half and turns off the lights to greatly reduce power consumption when the BSC is not in use while maintaining basic containment and cleanliness without the operator working with the cabinet. Typically, this mode is selected in the night or during lunchbreak or when the user is working on something else in the room.

At normal operation mode, slide the sash down until following conditions:

1. Sash opening at ± 2 inches (5 cm)
2. The sash is aligned with the yellow “standby” mark on the right side panel
3. Display shows standby mode
4. The lights are turning off and the blower shows half speed

While in Standby mode, the airflow monitor is disabled and only the FAN settings is operational; moreover, other options are interlocked.

3.1.6 Alarms and Warnings

BSC uses alarms to indicate that the condition inside the BSC is not safe for the operator, so check the LCD display to understand the cause of these alarms. The most common alarm is the SASH ALARM that indicates that the sash is neither at the normal operating height nor at a fully closed position (UV

mode) – this condition can easily be corrected by putting the sash at the appropriate operating position.

Other alarms that indicate a failure or an error in the BSC system:

- **ALARM: AIRFLOW FAIL** will be displayed if there is an airflow failure.
- **ALARM: SASH UNSAFE** will be displayed if the sash is neither at operating height nor fully closed. If this message displayed with sash status bar in “Sash: Error”, there is problem with mag switch or magnet.
- **ALERT: TEMP TOO HIGH** will be displayed if the ambient temperature is too high
- **ALERT: TEMP TOO LOW** will be displayed if the ambient temperature is too low
- **SENSOR UNCALIBRATED** will be displayed if the airflow velocity sensor is not yet calibrated.
- **ALARM: MODULE NOT RESPONSE** will be displayed if there is a communication problem between main board and I/O board



Figure 13. Alarm Airflow Fail

If airflow inflow velocity speed is too low, system will emit a visual and audible alarm. Main background will be turned to blinking red. Top Bar Status shows not safe condition. Inflow velocity speed shows actual value with red highlighted background.



Figure 14. Alarm Unsafe Sash Height

The main background will be turned to blinking red. Top Bar Status shows not safe condition. Sash status shows current opening sash windows with red background. Audible alarm in this condition is not allowed to be muted. Lift the sash window to a safe height opening.



Figure 15. Alarm Module Not Response

The system has smart self-diagnostics to detecting communication problems between the mainboard and I/O board. Communication problems will potentially cause the system to perform unwanted actions or display inaccurate values. In this case, it is strongly recommended that you stop work and then contact an authorized service engineer.



Figure 16. Sensor Uncalibrated



Figure 17. Ambient Temperature is Too Low



Figure 18. Ambient Temperature is Too High

Environmental temperature alarm will be displayed when the ambient temperature is too low or too high which is exceed the environmental requirement for the BSC operation.



Figure 19. Needs Re-certification

If the message “Cert. due date has passed!” is displayed, it means the BSC certification has expired. Call service or Escó’s local distributor for re-certification.

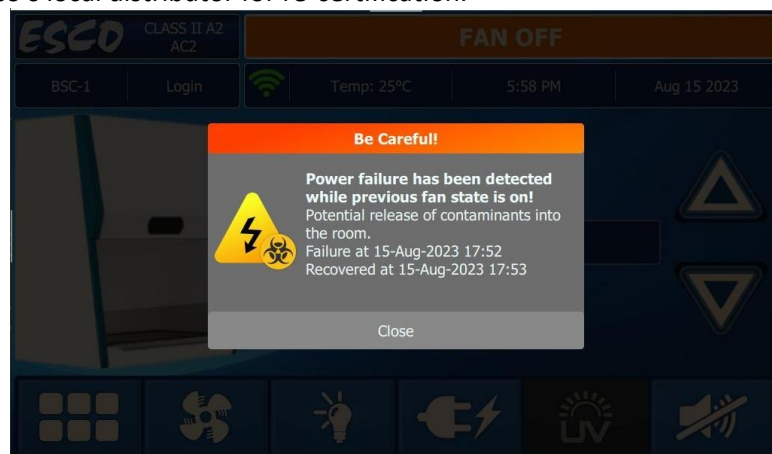
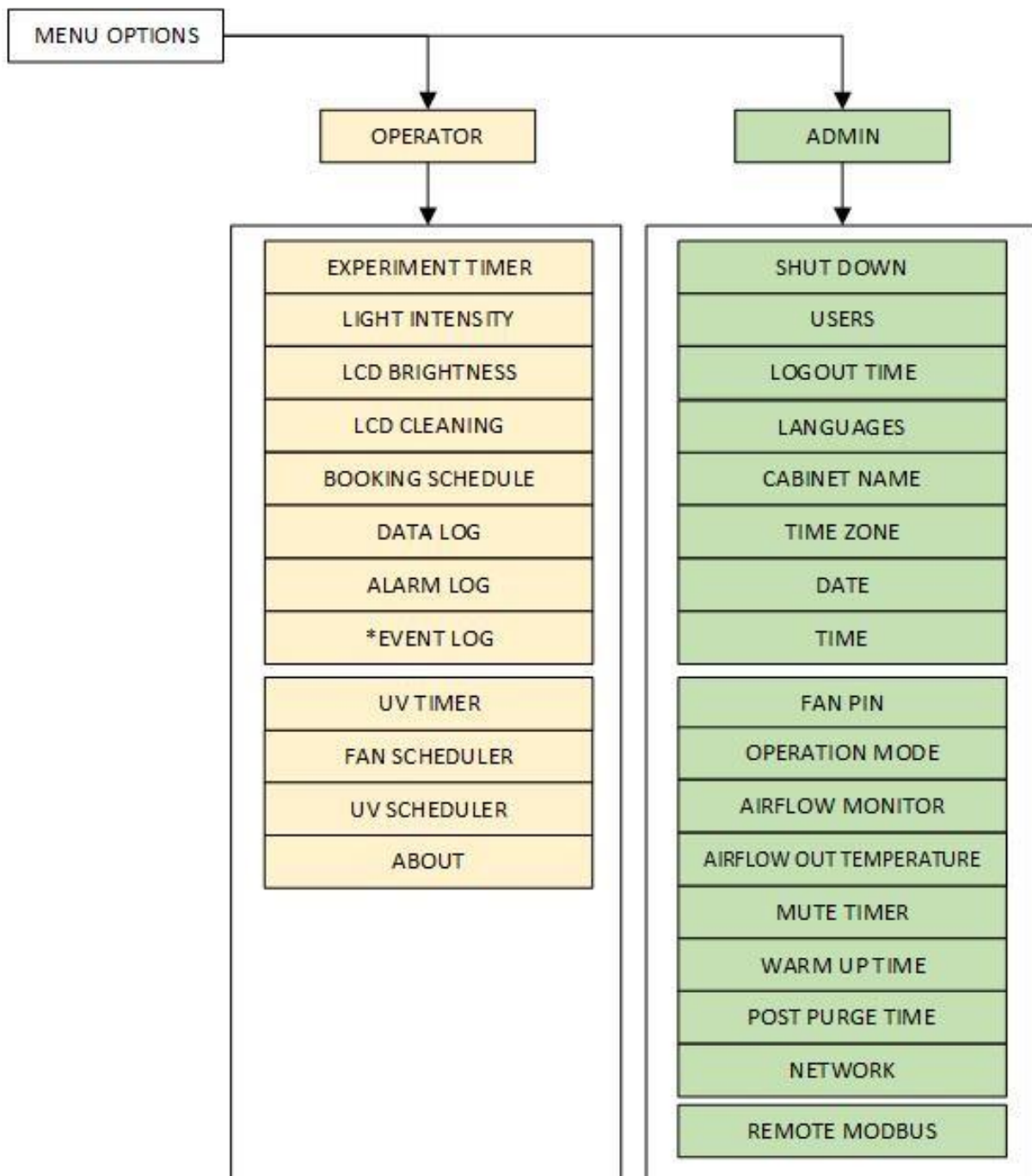

Figure 20. Warning of Release Contamination caused by Power Outage

The warning will be displayed when the power failure happened while BSC is in operation to inform the user regarding the potential of biohazard released.

3.2 Menu Options

Please refer to the following diagram for complete reference to all menu options available.



* Available only when the 21 CFR Part 11 feature is enabled

** Available only if the Sensor Constant is not equal to 0

Figure 21. Diagram of Menu







There are four-level access features inside the BSC menu (See *Annex 1* for User Access Level Table):

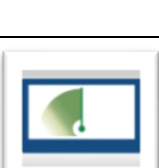

1. **Operator** - can access the basic function.

2. **Admin** – have the same privilege with Operator but can also make changes in the parameters.

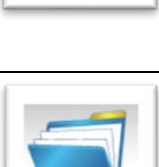
3.2.1. Operator



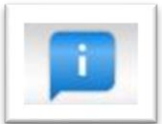

These are several sub-menus can be accessed by the operator, the following options are:







	<ul style="list-style-type: none"> • Experiment Timer Experiment timer is a countdown timer that can be used for the critical experiment. Experiment timer can be set between “00:00:00” and “23:59:59”.
	<ul style="list-style-type: none"> • Light Intensity It may be used to control the light intensity level of the LED brightness. It is recommended that the user adjust the settings according to their preference.
	<ul style="list-style-type: none"> • LCD Brightness LCD Brightness can be used to adjust the radiance of the touchscreen display using a sliding icon. It also features automatic dim function. User can choose from 1 to 5 minutes to save energy.
	<ul style="list-style-type: none"> • Clean LCD Clean LCD gives a 30 -second of the freeze display given to the user to clean the LCD by meantime usage.
	<ul style="list-style-type: none"> • Booking Schedule Define and schedule cabinet usage for multiple users. Register, edit, cancel, delete or export the cabinet usage booking schedule through Bluetooth or USB.
	<ul style="list-style-type: none"> • Data Log Data log shows the records of airflow (inflow and downflow) value periodically and this information can also be exported using a USB drive.
	<ul style="list-style-type: none"> • Alarm Log Alarm log shows the records of the type of alarm that occurs at a time.
	<ul style="list-style-type: none"> • Event Log This will display the description of the events including state of changes made in the BSC unit. The user can scroll down or up if the error message is too long. The Event Log can be exported using a USB drive.





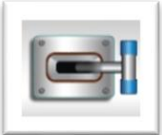

	<ul style="list-style-type: none"> • UV Timer <p>UV timer can be used to switch off the UV lamp automatically after a fixed period. The UV timer can be set up to 24 hours. By default, the timer is set to 60 minutes. Esco does not recommend leaving the UV lamp on for more than 60 minutes per decontamination cycle as it shortens the lifespan of the UV lamp. Unless the UV timer is activated, the lamp must be switched off manually.</p>
	<ul style="list-style-type: none"> • Fan Scheduler <p>To schedule the fan in order to turn on at designated time.</p>
	<ul style="list-style-type: none"> • UV Scheduler <p>To set UV Lamp on and off at a time when the user needs the BSC before starting work or sterilize the work zone as the user finishes working with the unit.</p>
	<ul style="list-style-type: none"> • About <p>There will show shortcut to see the cabinet diagnostics, quick tour and company information</p>

3.2.2. Administrator

The admin menu allows you to make changes to the authorized users who can make changes in the BSC. The reset blower, filter and UV hour meter (if present) functions are usually used after the blower, filter or UV lamp is changed as they can easily give the user the indication on when to maintain the BSC. The reset default function will return the options in the settings menu to their factory settings.

	<ul style="list-style-type: none"> • Shut Down <p>Shut down screens provide the way to turn off the BSC. See chapter 4.2.2 Turning off the BSC for the explanation on the submenu for shutdown.</p>
	<ul style="list-style-type: none"> • Users <p>This menu provides the list of users that can use the BSC.</p>
	<ul style="list-style-type: none"> • Log Out Time <p>This menu has a feature to set log out time</p>
	<ul style="list-style-type: none"> • Languages <p>Using this option, the user can select the language displayed on the LCD. Labculture® Class II Type A2 Biosafety Cabinet comes with English as the default language, but the user has an option to choose the desired language (such as Francaise, Espanol, and Italiano). This option must be specified when ordering the cabinet.</p>

	<ul style="list-style-type: none"> • Cabinet Name <p>This menu enables Admin to set cabinet's name.</p>
	<ul style="list-style-type: none"> • Time Zone <p>To set current time zone based on location</p>
	<ul style="list-style-type: none"> • Date <p>Users can set the date and it will be maintained even after the unit is turned off. The fixed format is MMM DD YYYY. Date update based on Network Time, to keep the time updated event RTC module not working in case the RTC battery is low.</p>
	<ul style="list-style-type: none"> • Time <p>Users can set the time and it will be maintained even after the unit is turned off. The format is HHMMSS. The user can configure the time format settings using the 12 or 24 -hours display format. Time Update based on Network Time, to keep the time updated event RTC module not working in case the RTC battery is low.</p>
	<ul style="list-style-type: none"> • Fan PIN <p>FAN PIN restricts access to fan control and some parts of the menu, settings and set mode. User must enter four-digit PIN before switching fan on or off. This feature prevents unauthorized personnel from accessing critical control sections. It will also prevent unauthorized shutdown of the BSC when continuous operation is required. Fan PIN is also needed to disable the alarm when the sash is fully raised and cleaning needs to be performed. Use 0000 to reset the Fan Pin.</p>
	<ul style="list-style-type: none"> • Airflow Monitor <p>By disabling the airflow monitor, the airflow measurement value will not be displayed on Home screen and the airflow alarm will be disabled.</p>
	<ul style="list-style-type: none"> • Operation Mode <p>This menu enables Admin to choose between 3 type of operation modes (Quick start, Normal and Maintenance):</p> <ol style="list-style-type: none"> 1. Normal Mode The normal mode is activated by factory default. In this mode, all alarms and interlocks are enabled. 2. Quickstart Mode Quickstart mode allows the user to activate the blower by simply lifting the sash from a fully closed position and the light by simply lifting the sash window to the operating position. In this mode, all alarms and interlocks are enabled. 3. Maintenance Mode Maintenance mode should only be accessed by qualified personnel during maintenance. In this mode, all alarms are disabled, and all interlocks are defeated.

	<ul style="list-style-type: none"> • Airflow out temp Using this option, the user can select whether or not to display the airflow when the ambient temperature is out of the optimum temperature range, below 18°C (65°F) or above 30°C (86°F).
	<ul style="list-style-type: none"> • Warm-Up Time There will be a warm-up period before the BSC is fully functioning upon activation of the unit. This is to ensure that the sensors, the blower, and the control system are stabilized, as well as to ensure the work zone is purged of contaminants. The default setting is 3 minutes and can be set between 3 minutes to 15 minutes (Note: Please note that WHO Laboratory Biosafety Manual (3rd edition) advocates 5 minutes of purging time prior to commencing of work while US Biosafety in Microbiological and Biomedical Laboratories (5th edition) advocates 4 minutes).
	<ul style="list-style-type: none"> • Post Purge Time After the user switches off the BSC blower, there will be a post-purge period, to ensure that all contaminants are purged from the work zone. The default setting is zero minute (disabled) and the user can set from 0 up to 15 minutes. It is recommended that BSC is purged for a minimum of 3 minutes after the work is complete. (Note: Please note that WHO Laboratory Biosafety Manual (3rd edition) advocates 5 minutes post purging time after work is completed while US Biosafety in Microbiological and Biomedical Laboratories (5th edition) advocates 4 minutes).
	<ul style="list-style-type: none"> • Network Wi-Fi is a wireless networking technology that allows Biosafety cabinet to interface with local network or Internet. This page contains function to scan available access point, connect to access point, delete existing connection and show current IP Address.
	<ul style="list-style-type: none"> • Mute Timer This option is used to set mute alarm for a certain period. The mute period can be set between 1, 5, or 15 minutes, the default value is 5 minutes.
	<ul style="list-style-type: none"> • Remote Modbus That allows Biosafety Cabinet to interface with external devices such as PC or Building Management System via Modbus protocol. Allow the users to monitor the cabinet status and control some of the cabinet features such as Lighting, Lighting Intensity, UV Lamp, Motorized Sash, Blower, Solenoid Valve for Gas, and Socket outlet through a local network. This feature will require Modbus TCP IP Software installed on Computer or Mobile phone.

3.3 Diagnostic Mode

The diagnostic mode can be accessed by tapping the iconic cabinet symbol or go to user menu then tap diagnostic. The diagnostic mode allows the user to know the condition of the BSC or help the service engineer during maintenance and troubleshooting.

On-Screen	Explanation
Serial Number	Shows serial number of the CABINET unit
Software Version	Shows the version of the firmware
Operation Mode	Shows which mode is active: NORMAL MODE, QUICKSTART MODE, MAINTENANCE, or STANDBY MODE
Sash State	Shows the current position of the sash
Fan State	Showing the actual duty cycle and the RPM
Fan Usage Meter	Fan Meter – increased by the minute. Example: 1h 3min
Filter Life	Shows percentage of filter life (based on filter hour meter or fan rpm)
UV Life	Shows the percentage of UV lamp life (based on UV Lamp Hour Meter)
UV Timer	Shows the UV timer value – default is 30 minutes. Maximum value is 00 minutes (infinite on)
Temperature Ambient	Shows current ambient temperature
Temperature ADC	Shows ADC value of current ambient temperature
Temperature Calibration	Shows the ambient temperature when the calibration is performed
Temperature Calibration ADC	Shows the ADC value of ambient temperature when the calibration is performed
ADC IFA	ADC value of current airflow sensor reading
ADC IFN	ADC value of Nominal Inflow point - based on calibration – based on field calibration
ADC IFF	ADC value of Minimum/Fail Inflow point - based on calibration
ADC IF2	ADC value of Nominal Inflow point - based on factory calibration
ADC IF1	ADC value of Minimum/Fail Inflow point - based on factory calibration
VEL.IFN	Nominal Inflow velocity - based on calibration
VEL IFF	Minimum/Fail Inflow velocity - based on calibration
VEL IF2	Nominal Inflow velocity - based on factory calibration
VEL IF1	Minimum/Fail Inflow velocity - based on factory calibration
VEL DFN	Nominal Downflow velocity - based on calibration
VEL DF2	Nominal Downflow velocity - based on factory calibration
Sensor Constant	Constant value of airflow sensor
Fan Nominal	Showing nominal duty cycle and nominal speed (RPM) of the fan-based on calibration
Fan Minimum	Showing minimum duty cycle and nominal speed (RPM) of the fan-based on calibration
Fan Stand By	Showing the standby duty cycle of the fan-based on calibration
Fan IF2	Showing the nominal duty cycle and nominal speed (RPM) of the fan-based on factory calibration
Fan IF1	Showing minimum duty cycle and nominal speed (RPM) of the fan-based on calibration
Fan IFS	Showing the standby duty cycle and standby speed (RPM) of the fan-based on factory calibration
Exhaust free relay contact	Shows blower activity.
Alarm Free relay contact	Shows cabinet's alarm activity.
M-Switch S1	Show Magnetic switch for sash height detector (fully opened)
M-Switch S2	Show Magnetic switch for sash height detector (safe height)
M-Switch S3	Show Magnetic switch for sash height detector (fully closed)
M-Switch S4	Show Magnetic switch for sash height detector (UV interlocked)
M-Switch S5	Show Magnetic switch for sash height detector (standby)
M- Switch S6	N/A
Module – Hybrid Digital/Input	Shows communication status of the hybrid digital on the module (input section)
Module – Hybrid Digital/Output	Shows communication status of the hybrid digital on the module (output section)
Module – Hybrid	Shows communication status to the hybrid analog module (input

On-Screen	Explanation
Analog/Input	section)
Module – Hybrid Analog/Output	Shows communication status to the hybrid analog module (output section)
Module RBM Com	Shows communication status to the RBM Com module (for motor communication)
Module Real Time Clock	Shows communication status to the RTC module
Module I/O Expander	Shows communication status to the IO Expander module
Environmental Temperature Range	Shows the acceptance range of ambient temperature for cabinet operation
Watchdog Counter	Shows the countdown timer of watchdog system (timer always reset to 60 indicates the system is running well)
RTC Date & Time	Shows the date and time of RTC module
Cabinet Up Time	Shows cabinet up time in single use. From turning on to turning off.
<i>For motorized sash (if present)</i>	
Sash cycle	Shows the cycle of sash moving. Maximum cycle is 16,000.
<i>For exhaust (if present)</i>	
EXHPA	EXHAUST PRESSURE ACTUAL-shows actual pressure value on the exhaust collar
EXHPN	Exhaust pressure nominal- shows nominal pressure value of the cabinet - based on calibration
EXHPF	Exhaust pressure fail- shows the fail point of the exhaust collar- based on the calibration

3.4 Additional Features

- **Screen Saver**

Screen saver appears 30 minutes after the display screen is locked. Screen saver will not appear if:

- The unit is in Maintenance Mode
- Any alarms active
- Warming up condition
- UV is turning on
- Experiment timer is running
- Sensor is uncalibrated

The user will be automatically logged out at the same time the screen saver is appeared. To return to the normal display, just swipe the screen once.

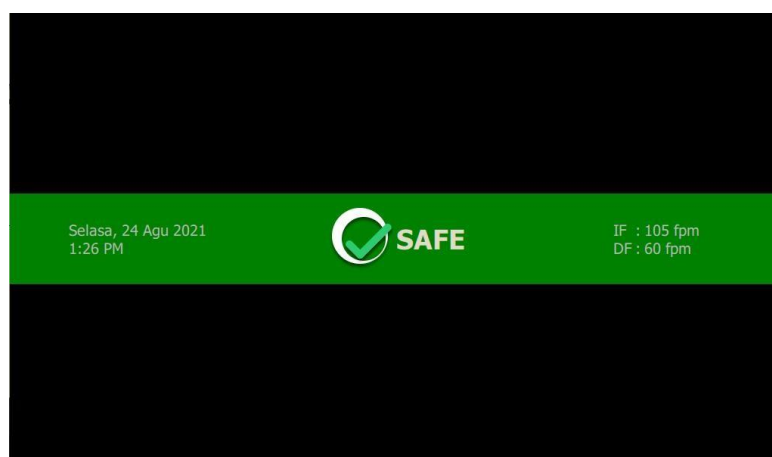

Figure 22. Screen Saver Mode during Normal Operation



Figure 23. Screen Saver during Standby Mode



Figure 24. Screen Saver during Turned Off Fan

- Screen Lock**
 Screen will be locked automatically after the user leaves the unit away for some minutes. The duration of the screen until it's locked follows the LCD dim timer. The LCD dim timer can be set in the LCD Brightness page. Swipe up the screen to unlock.

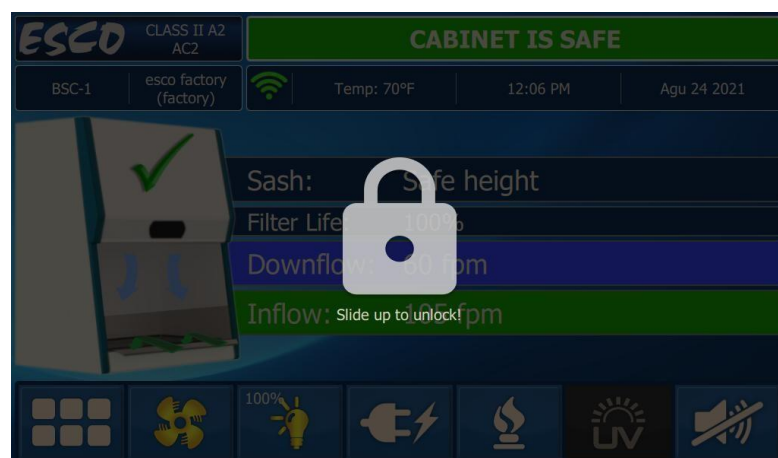

Figure 25. Lock Screen Feature

- **Screenshot**

Screenshot can be done by tapping and hold on the ESCO logo at the top-left side.



Figure 26. Screenshot Feature

Chapter 4 – Basic Cabinet Operation

4.1 Sash Window Operation

4.1.1 Sash Window State

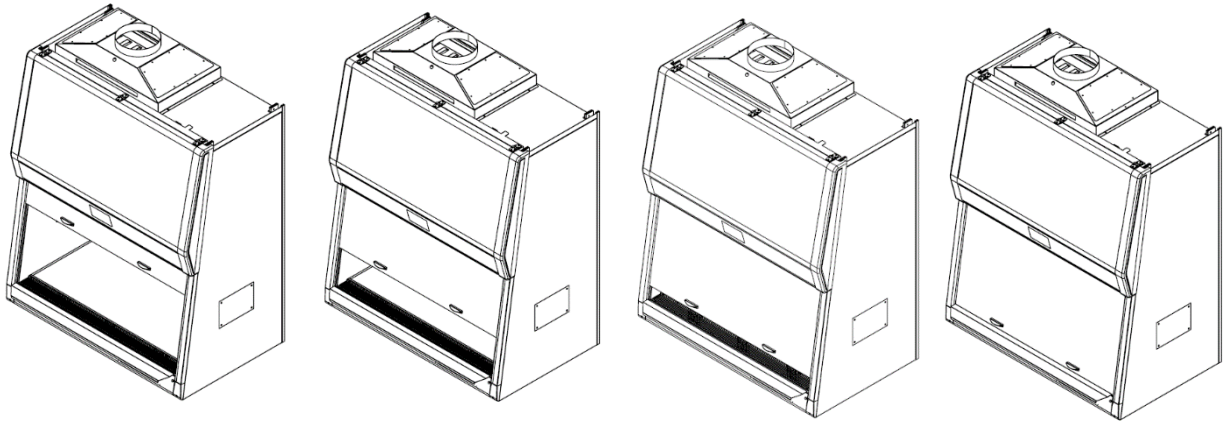

Figure 26 . Sash Window Positions

Sash is fully open

✓ Blower can be active

✓ LED Lamp can be used

✗ Unsafe working condition

Sash in safe position

✓ Blower can be activate

✓ LED Lamp can be used

✓ Safe working condition

Sash in Standby Mode

✓ Blower speed reduced to half

✗ LED Lamp can't be used

Sash is fully closed

✗ Blower can't be activated

✗ LED Lamp can't be used

✓ UV can be activated

4.1.2 Operating Motorized Sash Window (Only for BSC with Motorized Sash Window)

The motorized sash uses an automatic “one-tap” mechanism, so if you tap once on the triangular icons—upward or downward on the right side, the sash will adjust automatically to the nearest stop point of the height.



Figure 27. Unit with Motorized Sash Display

- **Raise Sash from Fully Closed Position**
When the sash is fully closed, tap once on the triangular upward icon. It will raise the sash automatically to a safe height. The next triangular upward icon tap from the safe height position will raise the sash to the fully opened position.
- **Lower Sash from Fully Open Position**
When the sash is fully opened, tap once on the triangular downward icon. It will lower the sash automatically to a safe height.
- **Lower Sash from Safe Height Position**
When the sash is in a safe height position, tap once on the triangular downward icon. It will lower the sash automatically and activate the standby mode. The next triangular downward icon tap from standby mode will move the sash to the fully closed position.

4.1.3 Using Sash Window

- The sash window should be fully closed when the cabinet is not in use. This helps keep the work zone interior clean.
- The sash window should always be in the normal operating height when the cabinet is in use. Even if the cabinet is left unattended, but the blower is on, the sash window should never be moved from the normal operating height, unless during loading or unloading of materials/apparatus into the cabinet.
- The alarm will be activated whenever the sash window is moved from the normal operating height.
- Whenever the sash window is moved to the correct height from a higher or lower position, the light will automatically be turned on as a signal to the user except standby mode.
- The sash window may be opened to its maximum position for the purpose of loading/unloading of materials/apparatus into the cabinet. When the sash window is fully opened, the alarm sound may be muted by tapping mute icon but the alarm will automatically sound again after 30 seconds (default is 30 seconds but can be set up to 5 minutes) to remind the user that it is not safe to work in the cabinet and the light will be turned on to facilitate cleaning.

4.2 Starting and Shutting Down the BSC

4.2.1 Turning on the BSC

1. Raise the sash to the indicated normal operational height (SAFE state). The lamp will be turned on when this height is reached (When Quickstart mode is selected, the blower will also automatically be activated).
2. Turn on the fan on the touchscreen display. Input the LOGIN if asked. The default password for LOGIN are 0000 for operator and 0001 for supervisor. This will start the warm-up procedure.
3. The BSC is ready for work.

4.2.2 Shutting Down the BSC

1. Shut down the BSC by tapping the shutdown icon in the admin sub-menu. Check the box stating that you are ready to shut down the unit. Thus, the shutdown option will be visible to tap.

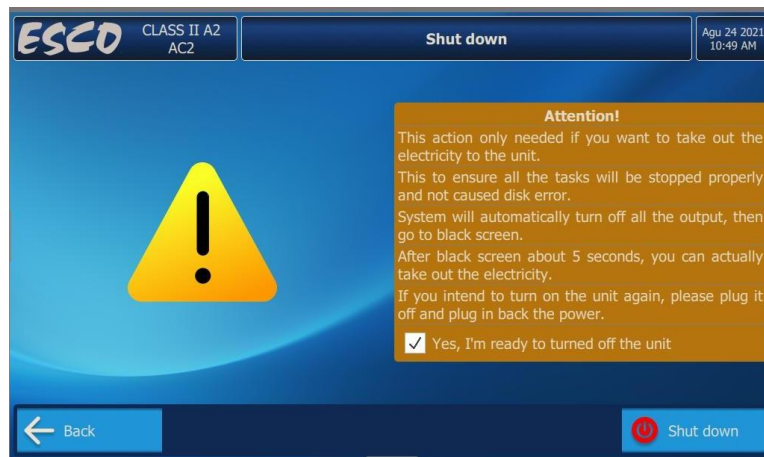

Figure 28. Shutdown Confirmation

2. Tap on the shutdown option.
3. If you wish to turn on the unit again, plug off then plug in back the power. The unit will be start automatically

4.3 Working in the BSC

- Allow the BSC to purge any contaminant by allowing the blower to operate for at least 3 minutes after using the BSC.
- Wear appropriate personal protective equipment (PPE) determined by your risk assessment prior to working in BSC.
- Adjust stool height to achieve a comfortable working position.
- Perform surface decontamination on the work area (work surface, back and side walls, UV lamp, electrical outlets, service fixtures and the inner surface of the sash window) before and after using the BSC. Filter diffuser should not be wiped to prevent filter damage. Where bleach is used, a second wiping with sterile water should be carried out to remove any residual chlorine that may corrode stainless steel surfaces.
- Perform surface decontamination on the surfaces of any materials, containers or apparatus with appropriate disinfectant before entering or exiting the work area.
- Place the waste container (biohazard bag, pipette discard pans, etc. inside the BSC work area.
- Place all items and apparatus in the safe working area.
- Minimize room activities (personnel movements, closing and opening of doors, etc.) since these external airflow disturbances may adversely affect the BSC's internal airflow, thereby possibly impairing the containment capabilities of the BSC.
- Ensure that the sash is at normal operating height (SAFE state) before starting any experiment.
- Ensure the front and back air grilles are not obstructed by your arms or any other objects.
- Work as far back in the BSC as possible - at least 150 mm (6 inches) behind the front air intake grille.
- Wait for around one minute after placing the hands into the cabinet prior to any manipulation.
- While working in the BSC, move your hands slowly and in a controlled manner. Rapid movements may disrupt the air barrier, allowing contaminants to escape or enter the BSC.
- The use of a Bunsen burner inside the work zone is not recommended. However, if the use of a Bunsen burner is unavoidable, a burner that is capable of being used on-demand or enclosed electric micro incinerator may be used but they must be placed towards the back of the work surface in the BSC.
- Place aerosol-generating instruments as far back in the BSC as possible and at least 150 mm

- (6 inches) from clean items/materials.
- Place air turbulence generating equipment such as centrifuges, blenders or sonicators towards the back of the BSC. Stop other work while any of this equipment is in operation.

4.4 Working Ergonomics

On most occasions, you would most likely be operating the BSC in sitting rather than standing posture. There are some obvious advantages of the sitting posture:

- The physiological energy cost and fatigue involved in sitting are relatively less.
- Sitting posture provides the body with stable support.

However, the sitting position has some drawbacks too:

- The working area available is fairly limited.
- There is a potential risk of being constrained in the same posture for a long time.
- Sitting posture is one of the most stressful postures for one's back.

Therefore you should pay careful attention to the following guidelines in order to achieve comfortable and healthy working conditions:

- Always ensure that your legs have enough legroom.
- Keep your lower back comfortably supported by your chair. Adjust the chair or use an appropriate pillow behind your back whenever necessary.
- You should place your feet flat on the floor or on a footrest. Don't dangle your feet and compress your thighs.
- You should keep varying your sitting position throughout the day at regular intervals so that you are never in the same posture for too long.
- Observe the following precautions with respect to your eyes:
 - Give your eyes frequent breaks. Periodically look away from the work area and focus at a distant point.
 - Keep your glasses clean.
- Arrange the items/apparatus frequently used in your work in such a way that you can minimize the physical strain involved in handling them.
- Exercise regularly.

The BSC's noise emission has been tested and found to be in compliance with EN 12469, ISO 4871 and NSF/ANSI 49 which is important to ensure health and comfort for the operator. Ergonomics accessories available from Esco include:

- Armrest padding.
- Lab chair.
- Footrest.

Please contact your local distributor or Esco for more information.

4.5 UV Lamp (If Present)

Shortwave UV (UVC) is considered as germicidal and virucidal. The UV lamp that Esco provides has a large portion of the spectrum in the UVC range. Unlike many other types of decontamination agents, UV light doesn't leave any residue. The decontamination action stops upon de-energizing of the lamp. However, the UVC spectrum does not penetrate well.

- UV light decontamination method may be used before and after working with susceptible organisms. However, it should not be the sole decontamination agent. A chemical decontamination agent should still be used.
- There should be a minimum amount of material inside the BSC's work area during the process of UV light decontamination. Direct interaction with UV light can degenerate

plastic- or rubber-based material and can cause other hazards (e.g. generation of hazardous vapors).

- Before activating the UV lamp, the BSC sash should be in a fully closed position and the user should ensure that interlock is working properly. Avoid direct contact with skin and eyes as UV light is classified as a probable human carcinogen.
- The UV timer feature should be used to easily control the decontamination period (Note: UV timer default setting is one hour). Leaving the UV lamp on for more than one hour or even overnight is not recommended because it shortens the lifespan of the lamp. The UV lamps used in Esco BSC have a lifespan of 2,000 hours.
- The UV lamp should be cleaned of any dust and dirt weekly and changed annually to ensure its effectiveness. Ensure that the lamp is turned off when lamp cleaning and maintenance is carried out.
- Please note that the use of a UV lamp in BSC has been explicitly discouraged in all major international standards and recommendations.

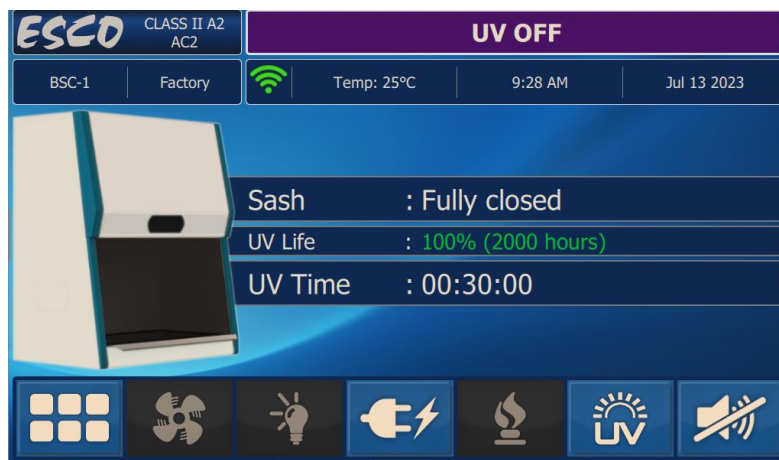

Figure 29. UV OFF Status

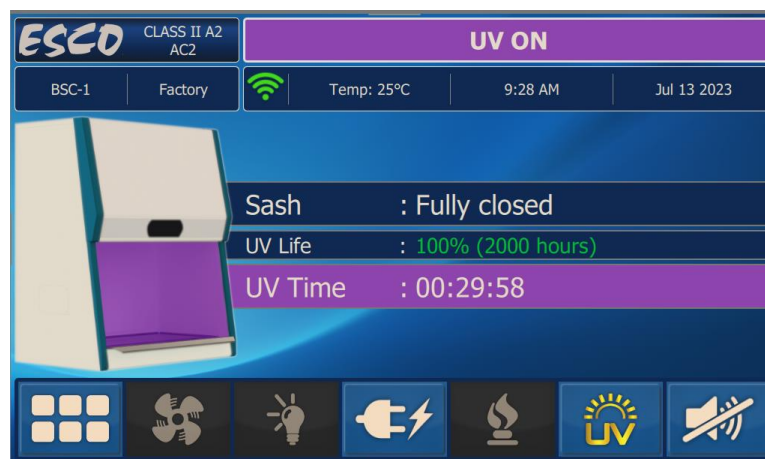

Figure 30. UV ON Status

4.6 Decontamination and Disinfecting Agent

- For stainless steel surfaces, all common disinfectant agents except chlorine-based ones are suitable. Where chlorine-based agents are used, sterile water should be used to rinse and wipe down the surfaces following the application of the disinfectant agents to avoid damage to the unit.

- For powder coated surfaces, all common disinfectant agents are suitable. However, the BSC has been specifically evaluated for use with the following:
 - 1N Sodium Hydroxide
 - 1% Quaternary Ammonium Compound
 - 5% Formaldehyde
 - 5,000 ppm Hypochlorite
 - 2% Iodophor
 - 5% Phenol
 - 70% Ethyl Alcohol

CETA Application Guide: Biological Decontamination and Disinfection of Accessible Surfaces in BSC

These are general comments for each chemical cited. The SDS and product label must be consulted prior to use.

Table 1. Tradeoffs of Commonly Used Disinfectants (CETA, 2019)

Disinfectant	Tradeoff Issues	
	Pros	Cons
Alcohols (Isopropyl or ethanol)	<ul style="list-style-type: none"> ✓ Short contact time ✓ Long shelf life ✓ Inexpensive and readily available 	<ul style="list-style-type: none"> ✗ Flammable ✗ Non sporicidal ✗ Affected by organic contaminants ✗ Quickly evaporates before adequate contact time
Chlorine dioxide (also used as a sterilant)	<ul style="list-style-type: none"> ✓ Broad spectrum ✓ Not corrosive to some surfaces as hypochlorite ✓ Available in solid and liquid formats 	<ul style="list-style-type: none"> ✗ Working solutions must be used quickly ✗ irritating to eyes, mucous membranes, skin and respiratory tract ✗ requires long contact time
Glutaraldehyde (Activated) Also used as a sterilant	<ul style="list-style-type: none"> ✓ Broad spectrum ✓ Unaffected by organic contaminants 	<ul style="list-style-type: none"> ✗ 14-day shelf life ✗ Pungent odor; irritating to eyes, skin and respiratory tract ✗ Requires long contact time ✗ Expensive
Hydrogen Peroxide	<ul style="list-style-type: none"> ✓ Broad spectrum ✓ Short contact time ✓ Leaves little to no residue ✓ Readily available 	<ul style="list-style-type: none"> ✗ Corrosive in higher concentrations ✗ Can cause chemical burns at higher concentrations ✗ Affected by organic contaminants
Iodophors (Iodine + surfactant))	<ul style="list-style-type: none"> ✓ Short contact time ✓ Long shelf life ✓ Readily available 	<ul style="list-style-type: none"> ✗ Non sporicidal ✗ Affected by organic contaminants ✗ Can be corrosive
Peroxide/Peracetic acid	<ul style="list-style-type: none"> ✓ Broad spectrum ✓ Unaffected by organic contaminants 	<ul style="list-style-type: none"> ✗ Pungent odor; irritating to eyes, skin and respiratory tract ✗ May cause chemical burns ✗ Ineffective when exposed to heat and/or light
Phenolic	<ul style="list-style-type: none"> ✓ Broad spectrum ✓ Unaffected by organic contaminants ✓ Long shelf life ✓ Readily available 	<ul style="list-style-type: none"> ✗ Pungent odor; irritating to eyes, skin and respiratory tract ✗ Non sporicidal ✗ EPA regulated disposal

Disinfectant	Tradeoff Issues	
	Pros	Cons
Quaternary ammonium compounds	<ul style="list-style-type: none"> ✓ Short contact time ✓ Long shelf life ✓ Compatible with many surfaces ✓ Less irritating than other disinfectants ✓ Low cost 	<ul style="list-style-type: none"> ✗ Effective only against viruses and vegetative bacteria ✗ Affected by organic contaminants ✗ Detergent-like properties

- Adequate contact time should be observed for effective decontamination and the contact time required depends on the disinfectant agents, the concentration and the object of disinfection.
- There is no one disinfectant agent that works with all organisms. Therefore, the user and the safety professionals should carry out a risk assessment on the anti-microbial effectiveness of the disinfectant to ensure that appropriate disinfectant agent and validated decontamination procedures are used in decontaminating the BSC.

Prior to beginning decontamination activity, it is recommended to follow these steps:

1. Put on Personal Protective Equipment (Latex/nitrile Gloves, Face Mask, and Lab Coat).
2. Make sure that the cabinet remains in operational mode with internal blower on.
3. Raise the sliding sash window to a full-open position. Silence the audible alarm during the cleaning process.
4. Clean all readily accessible surfaces of the cabinet and wipe all surfaces in parallel strokes from clean to dirty.

4.7 Gaseous Decontamination

Decontamination may frequently be carried out by means of Formaldehyde fumigation or using other decontamination agents, such as Chlorine Dioxide or Hydrogen Peroxide. The decontamination process should only be carried out by qualified personnel.

In any of the following eventualities, the user should ensure that the BSC has been properly decontaminated, keeping in mind the nature of the pathogens used:

- At the time of moving/relocating the BSC.
- At the time of changing the type of work being carried out in the BSC.
- Before accessing contaminated areas for servicing (e.g. when the filter needs replacement).
- Periodically and as mandated by your risk assessment.

4.7.1 Formalin/Paraformaldehyde Decontamination

Typically, the decontamination is performed using formalin gas by either vaporizing 37% formalin solution or by de-polymerization of solid paraformaldehyde.

Despite its widespread usage for decontamination, formalin gas presents the following health risks:

- External contact can cause irritation to the skin, eyes, and mucous membranes.
- Inhalation in small concentrations can cause coughing, nausea, and diarrhea.
- Inhalation in large concentrations can cause convulsions, coma, and death.
- Long term exposure can cause cancer.

According to OSHA [Occupational Safety and Health Administration (USA)], formaldehyde Short Term Exposure Level (STEL) is 2 ppm for 15 minutes exposure, 4 times a day, a minimum of 60 minutes in between exposures. Any additional local safety regulations should also be observed. Personnel should be given adequate training. The following links provide general guidelines on formaldehyde safety:

- Regulations (Standards - 29 CFR) Formaldehyde - 1910, Occupational Safety and Health Standards, OSHA (Occupational Safety and Health Administration), U.S. Department of Labor: <https://www.osha.gov/laws-regs/regulations/standardnumber/1910>
- OSHA Formaldehyde Fact sheet. Available at: <https://www.osha.gov/OshDoc/data/General/Facts/formaldehyde-factsheet.html>

4.7.2 Chlorine Dioxide Decontamination

Chlorine dioxide decontamination is performed by injecting chlorine gas (Cl₂) into a cylinder filled with solid sodium chlorite (NaClO₂), which generates the greenish-yellow chlorine dioxide gas (ClO₂). Chlorine dioxide decontamination is much faster than formalin. Being a true gas, it spreads quickly, without the need of pulsing the BSC's blower. It can rapidly kill the micro-organisms with high efficacy with just 1 hour of contact time. Users must note that the concentration of chlorine gas inside the cabinet must decrease to a safe level (e.g. by using a scrubber system) before the user should open the airtight seal. The Short-Term Permissible Exposure Limit (STEL) for Chlorine Dioxide gas is 0.3 ppm.

4.7.3 Hydrogen Peroxide Decontamination

Hydrogen peroxide (H₂O₂) decontamination is performed by flash vaporization of an aqueous peroxide mixture, creating a vapor that is distributed throughout the inside the BSC. STERIS and BIOQUELL are two major vendors of hydrogen peroxide generators. There are significant differences in operating principles.

- The STERIS principle is to avoid condensation on surfaces to minimize corrosion and optimize vapor distribution. The relative humidity inside the BSC must be lowered to 30% so that the remaining 70% relative humidity can be occupied by the hydrogen peroxide vapor.
- The BIOQUELL principle is to seek micro-condensation to achieve the kill. The generator releases tiny high-speed droplets inside the BSC.

Esco Bioatom™ is a hydrogen peroxide bio-decontamination system which employs a process of atomizing hydrogen peroxide sterilant to create dry fog after it is injected into the space. This system creates a charge on the atomized droplets as it passes through the nozzle. This process happens during injection stage then followed by dwell stage when the sterilant is settle on the surfaces of the chamber and any materials inside the chamber as contact time for the bio-decontamination process. The last stage is aeration where the sterilant evaporates to gas and is extracted to the Bioatom™ to be catalytically converted to oxygen and water.

There are four phases in bio decontamination: prime line, injection, dwell, and aeration phase.

1. Prime line	The prime line phase aims to make the sterilant line is fill by the hydrogen peroxide. This phase is to avoid the blank space or bubbles in the line that can caused the inconsistency mist of hydrogen peroxide. Prime line is usually taking a several minutes to complete.
2. Injection	During the injection phase, a constant flow of atomized hydrogen peroxide through the nozzle is maintained at the selected injection rate and air flow. The

	injection time is dependent on large of the chamber. It will take more time to inject the larger chamber.
3. Dwell	After injection have finished, the next phase is dwell. Dwell phases provide the atomized H ₂ O ₂ contacted to the surface of work area and decontaminated it. The dwell time usually spend 20 minutes.
4. Aeration	Once the dwell stage is done, the system will put the isolator on aeration process to facilitate decomposition of H ₂ O ₂ to fewer toxic components (i.e., water vapor and hydrogen) prior release. Operation Settings screen contains the set points of the system as well as the set points for the preset cycles and the display settings.

Hydrogen peroxide vapor is non-carcinogenic but highly effective against micro-organisms. It is readily available, has broad spectrum, requires short contact time, and leaves little to no residues on the surface. Hydrogen peroxide (H₂O₂) vapor breaks down under catalytic action to become air and water, making it environmentally friendly and it leaves no residues. The BSC is often aerated by ducting to speed up the breaking down of hydrogen peroxide vapor.

The time needed for the entire process is outlined below:

1	Set-up & sealing the BSC	½ hour	
2	Conditioning and decontamination cycle	½ - 1 ½ hour	
3	Ducting out H ₂ O ₂	H ₂ O ₂ generator doing aeration	½ hour 8 hours
4	Tear-down	½ hour	
TOTAL		2 - 3 hrs.	9½ - 10½ hrs.

For hydrogen peroxide decontamination, the BSC need to be equipped with two ports:

1. One port located in front opening or sidewall, penetrating the work zone area
2. One port located on top of the exhaust filter.

The generator used defines the port function as described below:

	Steris	Bioquell	ESCO Bioatom™
Hydrogen peroxide source	Injected into the BSC	Generated inside the BSC	Generated inside the BSC
Bottom front/ side port	Hydrogen peroxide introduction	Hydrogen peroxide re-introduction	Hydrogen peroxide re-introduction
Top port	Hydrogen peroxide extraction	Hydrogen peroxide extraction	Hydrogen peroxide extraction

- Decontamination Acceptances
The decontamination cycle with hydrogen peroxide is successful if:
 1. H₂O₂ concentration in the room is under PEL (Permissible Exposure Limit) value of the country, 0.5 or 1 ppm for 8 hours
 2. Change colour of CI from blue/violet to pink (depend on the CI used, please refer to the manufacturer instruction)

3. No growth indicated by no turbidity on TSB medium of negative control and decontaminated BI
4. Growth indicated by turbidity on the TSB medium of positive control

BSC Material Compatibility

Materials resistance to the exposure of vaporized and atomized H₂O₂ has been validated. Here is the list of BSC parts exposed by atomized H₂O₂ during decontamination cycle using **Bioquell** and **Mobile Bioatom™**:

- | | |
|------------------------|---------------------------------|
| 1. Sash and side glass | 8. Filters and filter gasket |
| 2. Inner liner | 9. Downflow and exhaust blowers |
| 3. Port cover | 10. Cable |
| 4. Work tray | 11. PAO port |
| 5. Electrical outlet | 12. Plenum |
| 6. Drain pan | 13. Red cover |
| 7. Diffuser | |

All above parts material has been proved to be resistant to the vaporized and atomized H₂O₂ with this procedure. Therefore, this decontamination cycle procedures do not affect the appearance or function of the BSC parts.

4.8 Further Information

- A Guide to Biosafety and Biological Safety Cabinets can be downloaded from <https://www.escolifesciences.com/products/class-ii-biological-safety-cabinet/airstream-class-ii-type-a2-biological-safety-cabinets-nsf-49-certified#accordioncatalogsAndBrochures>
- An educational video on “Working Safely in your Biological Safety Cabinet” is available for viewing at <http://www.youtube.com/watch?v=ZnUW1N-JJz8>

Chapter 5 – Service and Maintenance

5.1 Scheduled Maintenance

Proper and timely maintenance is crucial for trouble-free functioning of any device and your Esco BSC is no exception to this rule. We strongly recommend that you follow the maintenance schedule suggested hereunder in order to obtain optimal performance from your Esco BSC.

No	Description of Task to Perform	Maintenance to be carried out every						
		Day	Week	Month	Quarter	1 Year	2 Years	5 Years
1	Surface decontaminate the work zone	√						
2	LCD Cleaning and decontamination	√						
3	BSC power-up alarm verification	√						
4	Clean the sash window	√						
5	Perform thorough surface decontamination on the drain pan		√					
6	Check the paper catch for retained materials		√					
7	Clean UV lamp (where present) of any dust and dirt		√					
8	Clean the exterior surfaces of the BSC			√				
9	Check all service fixtures (where present) for proper operation			√				
10	Inspect the BSC for any physical abnormalities or malfunction				√			
11	Clean stubborn stains on stainless steel surfaces with MEK				√			
12	Recertification					√		
13	Check the cabinet's functionality					√		
14	Change UV Lamp (where present)					√		
15	LED lamp(s) functionality annual inspection					√		
16	Check the sash window (parts, nuts, screws, rope/belt, smooth movement)					√		
17	Replace sash motor (for motorized sash window)							√
18	Inspect the Canopy (Exhaust Collar with Alarm) for any physical abnormalities or malfunction			√				

Cleaning and Disinfection BSC of work area

- Clean the work surface and walls with an appropriate disinfectant and soapy water afterward.
- Clean the sash window with appropriate disinfectant and glass cleaner afterward.
- Use a damp cloth to clean the exterior surface of the BSC, particularly on the front and top in order to remove dust that has accumulated there.
- Use sterile water to finish the cleaning and wash away any residue of disinfectant, soapy water, and glass cleaner.
- For removing stubborn stains or spots on the stainless steel surface, make use of MEK (Methyl-Ethyl- Ketone). In such cases, make sure that you wash the steel surface immediately afterward with sterile water and some liquid detergent. Use a polyurethane cloth or sponge for washing. Regular cleaning of the stainless steel surface helps retain the attractive factory finish.
- Ensure that the chemicals used are compatible with one another.
- Use appropriate personal protective equipment (PPE) when carrying out the activity.

LCD Surface Cleaning and Disinfection

Dust and fingerprint for most are the major concerns of cleaning LCD screen. However, besides work zone, LCD screen is also one of the germiest parts. Center for Disease Control and Prevention (CDC) is recommending to disinfect “high touch surfaces” when possible, including touchscreen. Here are some tips on how to clean and disinfect your BSC LCD surface:

- Use clean wiper to wipe softly
- Get the clean wiper prepped with cleaning solution (Isopropyl Alcohol 70% is recommended)
- Never directly apply cleaning solution to the touch screen
- Start in the center and gently wipe the screen in a circular motion
- Do not use the moist section of your cloth to clean the corners of the screen
- Gently wipe down the screen until the entire surface becomes clean and no longer has dust or dirt



Figure 31. Cleaning the LCD

Test the Audible and Visual Alarm

The simplest method by far would be to move the sash until the glass window is no longer in the sash ready or UV mode position.

Check the cabinet's functionality

- Check the BSC's mechanical functionality (e.g. sash window).
- Check the BSC's electrical functionality (e.g. LED lamp – replace if necessary).
- Check the BSC for any defect and if any, repair immediately.

Recertification

All BSC must be re-certified annually by a certified engineer. See certification procedures attached to the factory test report.

Accessing the paper catch (if any/present)

The purpose of accessing the paper catch is to remove any retained materials that might cause obstructions to airflow. Care must be taken as the area is contaminated.

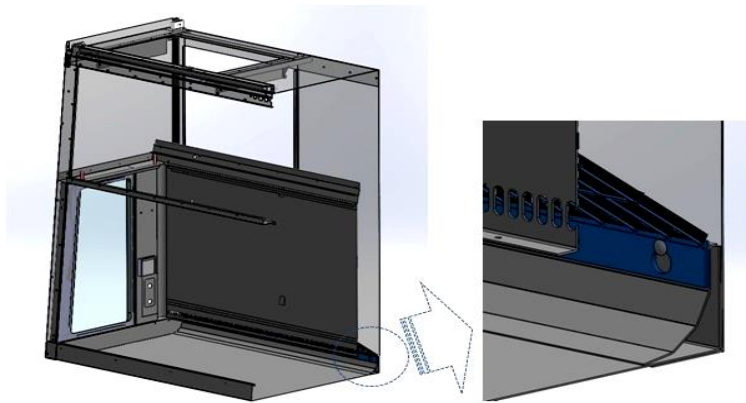

Accessing the paper catch:

1. Turn off the blower then raise the sash to fully open position for easy access.
2. Remove the tray(s) to access the paper catch.
3. As detailed, the paper catch is being hooked into two hooking objects at the back. Raise the paper catch initially up to 10mm until it feels like it disengages from those hooking objects, pull a bit to the front then do steps 1 to 3 below. Be careful of any sharp objects that might be present. You might want to use a mirror to help you assess the presence of hazardous materials prior to accessing the paper catch. Removed any materials that have been trapped.

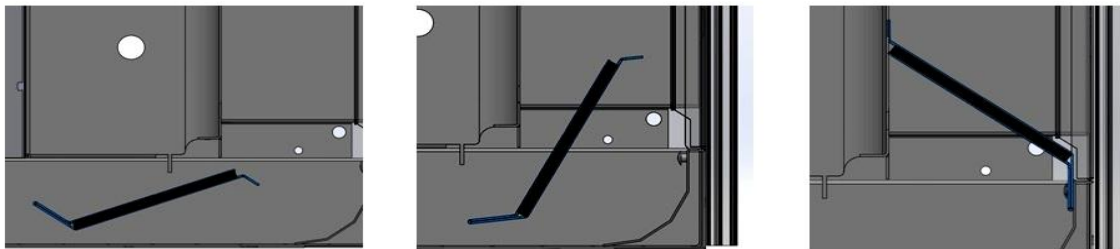
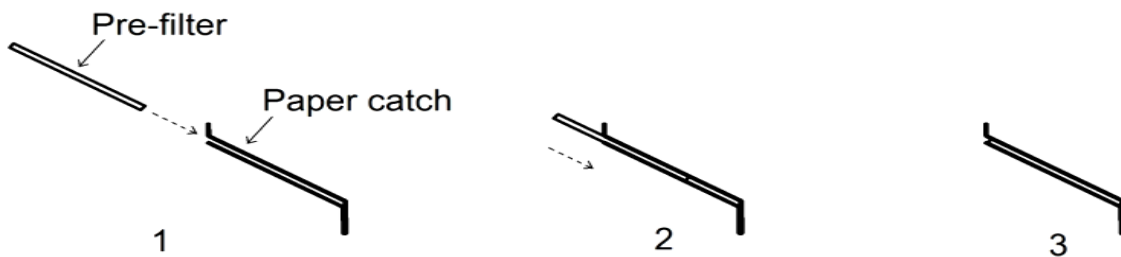

Figure 32. Paper Catch Access

Figure 33. Installation of Pre-filter

Pre-filter Installation:



1. Insert the pre-filter to the opening of the paper catch as shown in image 1 above.
2. Push the pre-filter accordingly until it fits into the paper catch as shown in image 2 to 3.

5.2 Maintenance/Service Log

It is good practice (and in some cases regulatory requirement) to maintain a log of all maintenance work carried out on your cabinet.